

TROCHOID
Torisch (mit ER)

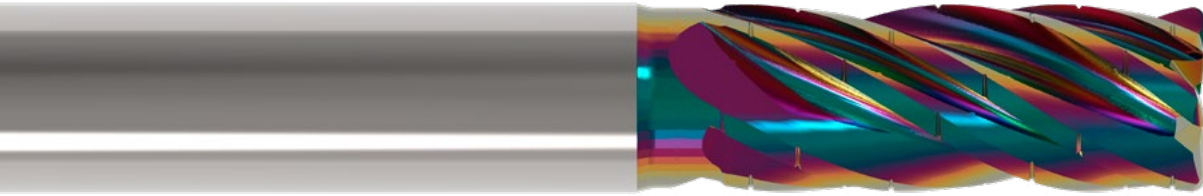

ACTIONMILL[®]
by HB microtec
Trochoid

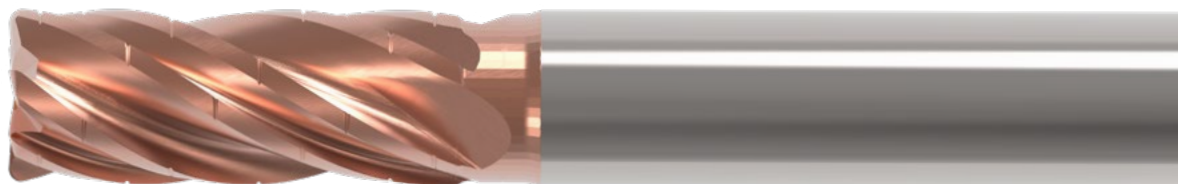
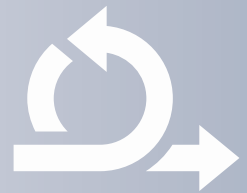

INOX-Trochoid

Alu-Trochoid

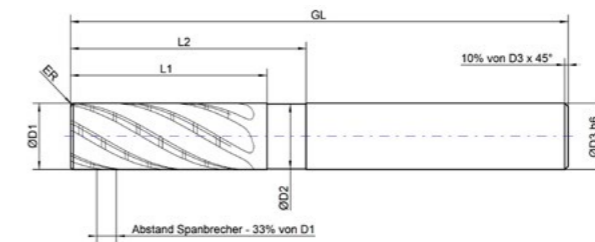
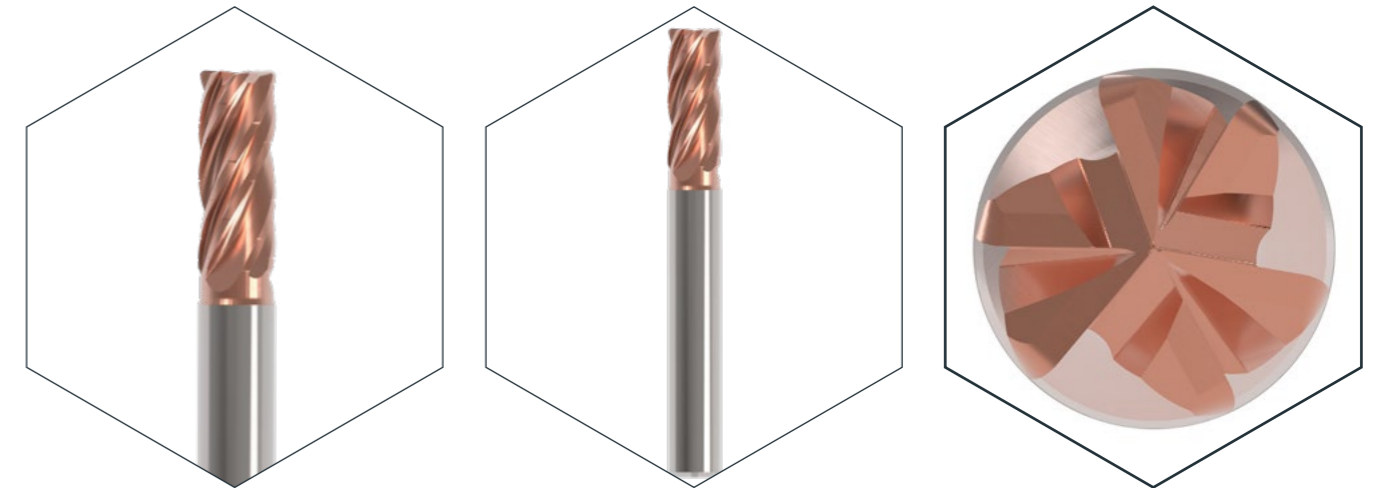
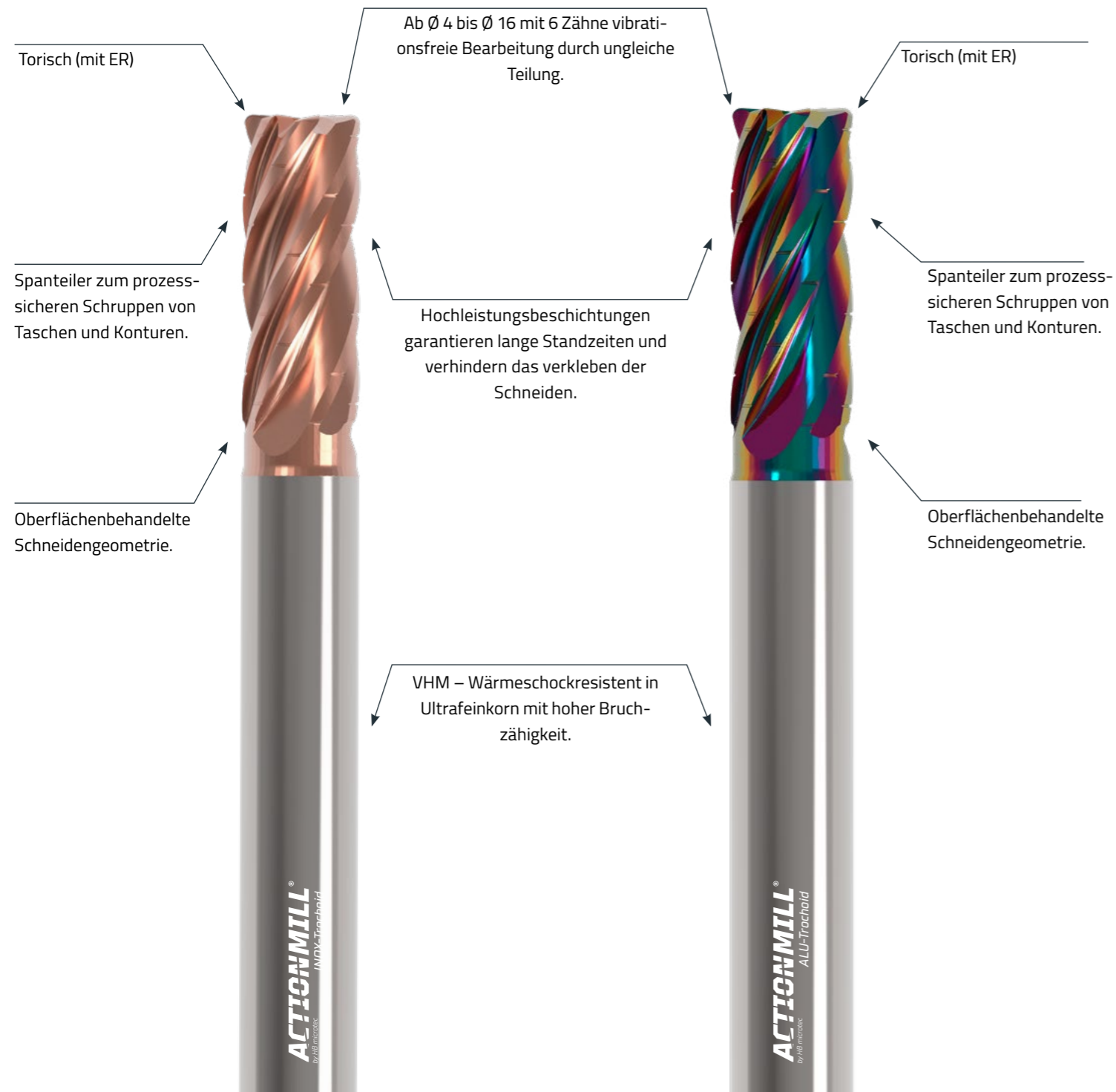

Bestellung Bestellnummer: _____ Anfrage

Abmessungen: D ₁ : _____ GL: _____ ER: _____ D ₂ : _____ L ₁ : _____ Z: _____ D ₃ : _____ L ₂ : _____		Beschichtung: Beschichtet*: _____ Unbeschichtet	Kühlkanäle: Ja Nein _____
Zu zerspanender Werkstoff: _____		Schaftform: _____	Schneidrichtung: Links Rechts _____
Datum, Unterschrift & Firmenstempel: _____			Menge: _____
			Kontaktperson: _____

* Ohne weitere Angaben wird die am besten passende Beschichtung verwendet.

2xD INOX-Trochoid Torisch

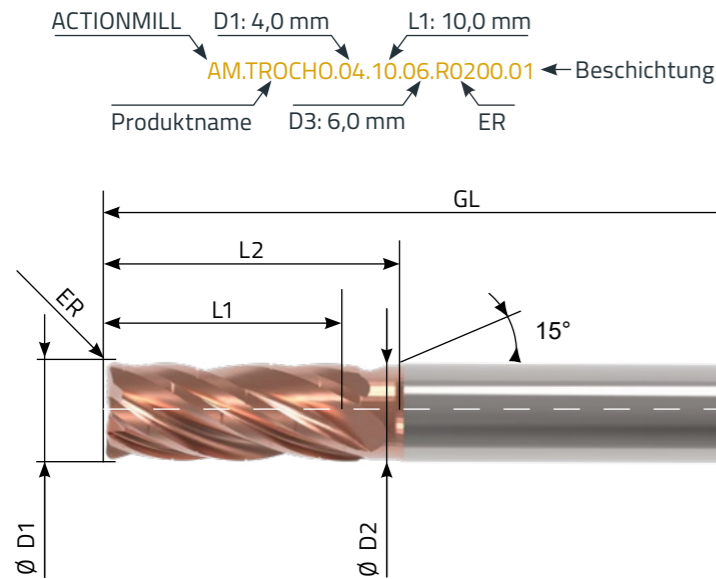
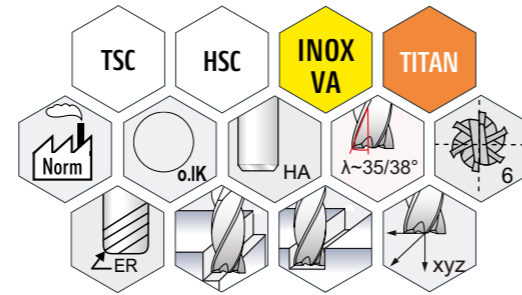

■ α-INOX beschichtet



5x PLUS für den ACTIONMILL:

- Vibrationsfreie Bearbeitung durch ungleiche Teilung
- Spezielle Schneidkantenausführung zur Schwingungsdämpfung
- Innere Kühlschmierstoff-Zufuhr, Y-Austritt
- Spanteilergeometrie zum prozesssicheren Schrappen von Taschen und Konturen
- Eckenradien stabilisieren den Fräser zusätzlich

Artikelnummer	D1 (mm)	D1 (inch)	D2 (mm)	D3 h6 (mm)	L1 (mm)	L2 (mm)	ER (mm)	ER (inch)	GL (mm)	HB-Schaft
AM.TROCHO.03968.10.06.R0254.01	Ø 3,968	Ø 5/32"	Ø 3,80	Ø 6,00	10,00	18,00	0,254	0,01	58,00	.HB
AM.TROCHO.04.10.06.R0200.01	Ø 4,000	-	Ø 3,80	Ø 6,00	10,00	18,00	0,200	-	58,00	.HB
AM.TROCHO.04.10.06.R0300.01	Ø 4,000	-	Ø 3,80	Ø 6,00	10,00	18,00	0,300	-	58,00	.HB
AM.TROCHO.04762.14.06.R0254.01	Ø 4,762	Ø 3/16"	Ø 4,50	Ø 6,00	14,00	20,00	0,254	0,01	58,00	.HB
AM.TROCHO.05.14.06.R0200.01	Ø 5,000	-	Ø 4,80	Ø 6,00	14,00	20,00	0,200	-	58,00	.HB
AM.TROCHO.05.14.06.R0300.01	Ø 5,000	-	Ø 4,80	Ø 6,00	14,00	20,00	0,300	-	58,00	.HB
AM.TROCHO.05556.14.06.R0254.01	Ø 5,556	Ø 7/32"	Ø 5,20	Ø 6,00	14,00	22,00	0,254	0,01	58,00	.HB
AM.TROCHO.06.14.06.R0200.01	Ø 6,000	-	Ø 5,70	Ø 6,00	14,00	22,00	0,200	-	58,00	.HB
AM.TROCHO.06.14.06.R0300.01	Ø 6,000	-	Ø 5,70	Ø 6,00	14,00	22,00	0,300	-	58,00	.HB
AM.TROCHO.06.14.06.R0500.01	Ø 6,000	-	Ø 5,70	Ø 6,00	14,00	22,00	0,500	-	58,00	.HB
AM.TROCHO.0635.14.08.R0254.01	Ø 6,350	Ø 1/4"	Ø 6,00	Ø 8,00	14,00	22,00	0,254	0,01	64,00	.HB
AM.TROCHO.0635.14.08.R0508.01	Ø 6,350	Ø 1/4"	Ø 6,00	Ø 8,00	14,00	22,00	0,508	0,02	64,00	.HB
AM.TROCHO.7144.18.08.R0254.01	Ø 7,144	Ø 9/32"	Ø 6,90	Ø 8,00	18,00	26,00	0,254	0,01	64,00	.HB
AM.TROCHO.7144.18.08.R0508.01	Ø 7,144	Ø 9/32"	Ø 6,90	Ø 8,00	18,00	26,00	0,508	0,02	64,00	.HB
AM.TROCHO.7144.18.08.R0762.01	Ø 7,144	Ø 9/32"	Ø 6,90	Ø 8,00	18,00	26,00	0,762	0,03	64,00	.HB
AM.TROCHO.7938.18.08.R0254.01	Ø 7,938	Ø 5/16"	Ø 7,80	Ø 8,00	18,00	26,00	0,254	0,01	64,00	.HB
AM.TROCHO.7938.18.08.R0508.01	Ø 7,938	Ø 5/16"	Ø 7,80	Ø 8,00	18,00	26,00	0,508	0,02	64,00	.HB
AM.TROCHO.7938.18.08.R0762.01	Ø 7,938	Ø 5/16"	Ø 7,80	Ø 8,00	18,00	26,00	0,762	0,03	64,00	.HB
AM.TROCHO.08.18.08.R0500.01	Ø 8,000	-	Ø 7,80	Ø 8,00	18,00	26,00	0,500	-	64,00	.HB
AM.TROCHO.08.18.08.R0750.01	Ø 8,000	-	Ø 7,80	Ø 8,00	18,00	26,00	0,750	-	64,00	.HB
AM.TROCHO.08.18.08.R1000.01	Ø 8,000	-	Ø 7,80	Ø 8,00	18,00	26,00	1,000	-	64,00	.HB
AM.TROCHO.9525.22.10.R0508.01	Ø 9,525	Ø 3/8"	Ø 9,20	Ø 10,00	22,00	32,00	0,508	0,02	73,00	.HB
AM.TROCHO.9525.22.10.R0762.01	Ø 9,525	Ø 3/8"	Ø 9,20	Ø 10,00	22,00	32,00	0,762	0,03	73,00	.HB
AM.TROCHO.9525.22.10.R1016.01	Ø 9,525	Ø 3/8"	Ø 9,20	Ø 10,00	22,00	32,00	1,016	0,04	73,00	.HB
AM.TROCHO.10.22.10.R0500.01	Ø 10,000	-	Ø 9,70	Ø 10,00	22,00	32,00	0,500	-	73,00	.HB
AM.TROCHO.10.22.10.R0750.01	Ø 10,000	-	Ø 9,70	Ø 10,00	22,00	32,00	0,750	-	73,00	.HB
AM.TROCHO.10.22.10.R1000.01	Ø 10,000	-	Ø 9,70	Ø 10,00	22,00	32,00	1,000	-	73,00	.HB
AM.TROCHO.10.22.10.R1250.01	Ø 10,000	-	Ø 9,70	Ø 10,00	22,00	32,00	1,250	-	73,00	.HB
AM.TROCHO.111125.26.12.R0508.01	Ø 11,1125	Ø 7/16"	Ø 10,80	Ø 12,00	26,00	36,00	0,508	0,02	84,00	.HB
AM.TROCHO.111125.26.12.R0762.01	Ø 11,1125	Ø 7/16"	Ø 10,80	Ø 12,00	26,00	36,00	0,762	0,03	84,00	.HB
AM.TROCHO.111125.26.12.R1016.01	Ø 11,1125	Ø 7/16"	Ø 10,80	Ø 12,00	26,00	36,00	1,016	0,04	84,00	.HB
AM.TROCHO.12.26.12.R0500.01	Ø 12,000	-	Ø 11,70	Ø 12,00	26,00	36,00	0,500	-	84,00	.HB
AM.TROCHO.12.26.12.R0750.01	Ø 12,000	-	Ø 11,70	Ø 12,00	26,00	36,00	0,750	-	84,00	.HB
AM.TROCHO.12.26.12.R1000.01	Ø 12,000	-	Ø 11,70	Ø 12,00	26,00	36,00	1,000	-	84,00	.HB
AM.TROCHO.12.26.12.R1250.01	Ø 12,000	-	Ø 11,70	Ø 12,00	26,00	36,00	1,250	-	84,00	.HB
AM.TROCHO.12700.26.14.R0508.01	Ø 12,700	Ø 1/2"	Ø 12,40	Ø 14,00	28,00	36,00	0,508	0,02	84,00	.HB
AM.TROCHO.12700.26.14.R0762.01	Ø 12,700	Ø 1/2"	Ø 12,40	Ø 14,00	28,00	36,00	0,762	0,03	84,00	.HB
AM.TROCHO.12700.26.14.R1016.01	Ø 12,700	Ø 1/2"	Ø 12,40	Ø 14,00	28,00	36,00	1,016	0,04	84,00	.HB
AM.TROCHO.12700.26.14.R1270.01	Ø 12,700	Ø 1/2"	Ø 12,40	Ø 14,00	28,00	36,00	1,270	0,05	84,00	.HB
AM.TROCHO.12700.26.14.R1524.01	Ø 12,700	Ø 1/2"	Ø 12,40	Ø 14,00	28,00	36,00	1,524	0,06	84,00	.HB
AM.TROCHO.14.28.24.R1000.01	Ø 14,000	-	Ø 13,70	Ø 14,00	31,00	40,00	1,000	-	84,00	.HB
AM.TROCHO.14.28.24.R1250.01	Ø 14,000	-	Ø 13,70	Ø 14,00	31,00	40,00	1,250	-	84,00	.HB
AM.TROCHO.14.28.24.R1500.01	Ø 14,000	-	Ø 13,70	Ø 14,00	31,00	40,00	1,500	-	84,00	.HB
AM.TROCHO.142875.29.16.R0762.01	Ø 14,2875	Ø 9/16"	Ø 13,90	Ø 16,00	32,00	40,00	0,762	0,03	83,00	.HB
AM.TROCHO.142875.29.16.R1016.01	Ø 14,2875	Ø 9/16"	Ø 13,90	Ø 16,00	32,00	40,00	1,016	0,04	83,00	.HB
AM.TROCHO.142875.29.16.R1270.01	Ø 14,2875	Ø 9/16"	Ø 13,90	Ø 16,00	32,00	40,00	1,270	0,05	83,00	.HB
AM.TROCHO.142875.29.16.R1524.01	Ø 14,2875	Ø 9/16"	Ø 13,90	Ø 16,00	32,00	40,00	1,524	0,06	83,00	.HB
AM.TROCHO.15875.32.16.R0762.01	Ø 15,875	Ø 5/8"	Ø 15,50	Ø 16,00	35,00	43,00	0,762	0,03	83,00	.HB
AM.TROCHO.15875.32.16.R1016.01	Ø 15,875	Ø 5/8"	Ø 15,50	Ø 16,00	35,00	43,00	1,016	0,04	83,00	.HB
AM.TROCHO.15875.32.16.R1270.01	Ø 15,875	Ø 5/8"	Ø 15,50	Ø 16,00	35,00	43,00	1,270	0,05	83,00	.HB
AM.TROCHO.15875.32.16.R1524.01	Ø 15,875	Ø 5/8"	Ø 15,50	Ø 16,00	35,00	43,00	1,524	0,06	83,00	.HB
AM.TROCHO.16.32.16.R1000.01	Ø 16,000	-	Ø 15,70	Ø 16,00	35,00	43,00	1,000	-	83,00	.HB
AM.TROCHO.16.32.16.R1250.01	Ø 16,000	-	Ø 15,70	Ø 16,00	35,00	43,00	1,250	-	83,00	.HB
AM.TROCHO.16.32.16.R1500.01	Ø 16,000	-	Ø 15,70	Ø 16,00	35,00	43,00	1,500	-	83,00	.HB

■ Für einen Fräser mit HB-Schaft ergänzen Sie „HB“ an die Artikelnummer, z. B. AM.TROCHO.04.10.06.R0200.01.HB

Ab Lager lieferbar.

3xD INOX-Trochoid Torisch

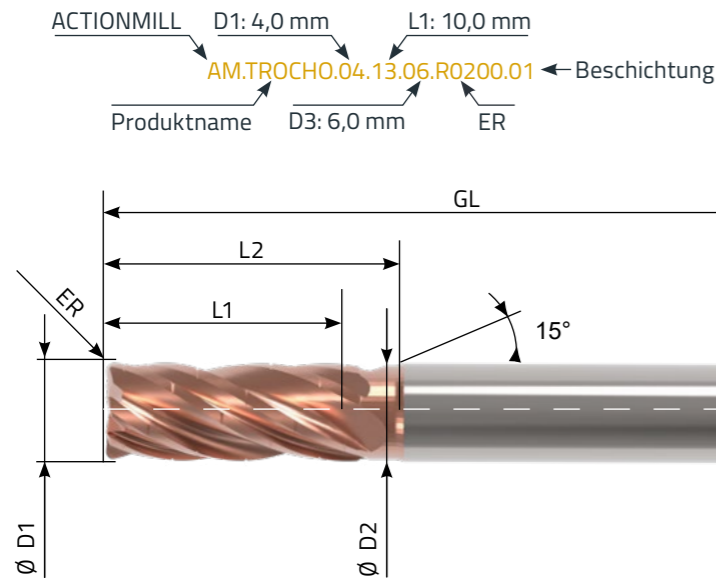
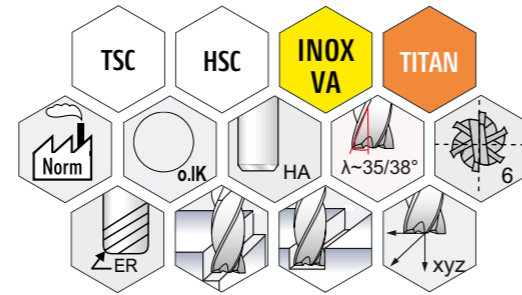

■ α-INOX beschichtet



5x PLUS für den ACTIONMILL:

- Vibrationsfreie Bearbeitung durch ungleiche Teilung
- Spezielle Schneidkantenausführung zur Schwingungsdämpfung
- Innere Kühlschmierstoff-Zufuhr, Y-Austritt
- Spanteilergeometrie zum prozesssicheren Schrappen von Taschen und Konturen
- Eckenradien stabilisieren den Fräser zusätzlich

Artikelnummer	D1 (mm)	D1 (inch)	D2 (mm)	D3 h6 (mm)	L1 (mm)	L2 (mm)	ER (mm)	ER (inch)	GL (mm)	HB-Schaft
AM.TROCHO.03968.13.06.R0254.01	Ø 3,968	5/32"	Ø 3,80	Ø 6,00	13,00	18,00	0,254	0,01	58,00	.HB
AM.TROCHO.04.13.06.R0200.01	Ø 4,000	-	Ø 3,80	Ø 6,00	13,00	18,00	0,200	-	58,00	.HB
AM.TROCHO.04.13.06.R0300.01	Ø 4,000	-	Ø 3,80	Ø 6,00	13,00	18,00	0,300	-	58,00	.HB
AM.TROCHO.04762.15.06.R0254.01	Ø 4,762	3/16"	Ø 4,50	Ø 6,00	15,00	20,00	0,254	0,01	58,00	.HB
AM.TROCHO.05.15.06.R0200.01	Ø 5,000	-	Ø 4,80	Ø 6,00	15,00	20,00	0,200	-	58,00	.HB
AM.TROCHO.05.15.06.R0300.01	Ø 5,000	-	Ø 4,80	Ø 6,00	15,00	20,00	0,300	-	58,00	.HB
AM.TROCHO.05556.18.06.R0254.01	Ø 5,556	7/32"	Ø 5,20	Ø 6,00	18,00	22,00	0,254	0,01	58,00	.HB
AM.TROCHO.06.18.06.R0200.01	Ø 6,000	-	Ø 5,70	Ø 6,00	18,00	22,00	0,200	-	58,00	.HB
AM.TROCHO.06.18.06.R0300.01	Ø 6,000	-	Ø 5,70	Ø 6,00	18,00	22,00	0,300	-	58,00	.HB
AM.TROCHO.06.18.06.R0500.01	Ø 6,000	-	Ø 5,70	Ø 6,00	18,00	22,00	0,500	-	58,00	.HB
AM.TROCHO.0635.20.08.R0254.01	Ø 6,350	1/4"	Ø 6,00	Ø 8,00	20,00	24,00	0,254	0,01	64,00	.HB
AM.TROCHO.0635.20.08.R0508.01	Ø 6,350	1/4"	Ø 6,00	Ø 8,00	20,00	24,00	0,508	0,02	64,00	.HB
AM.TROCHO.7144.22.08.R0254.01	Ø 7,144	9/32"	Ø 6,90	Ø 8,00	22,00	26,00	0,254	0,01	64,00	.HB
AM.TROCHO.7144.22.08.R0508.01	Ø 7,144	9/32"	Ø 6,90	Ø 8,00	22,00	26,00	0,508	0,02	64,00	.HB
AM.TROCHO.7144.22.08.R0762.01	Ø 7,144	9/32"	Ø 6,90	Ø 8,00	22,00	26,00	0,762	0,03	64,00	.HB
AM.TROCHO.7938.24.08.R0254.01	Ø 7,938	5/16"	Ø 7,80	Ø 8,00	24,00	28,00	0,254	0,01	64,00	.HB
AM.TROCHO.7938.24.08.R0508.01	Ø 7,938	5/16"	Ø 7,80	Ø 8,00	24,00	28,00	0,508	0,02	64,00	.HB
AM.TROCHO.7938.24.08.R0762.01	Ø 7,938	5/16"	Ø 7,80	Ø 8,00	24,00	28,00	0,762	0,03	64,00	.HB
AM.TROCHO.08.24.08.R0500.01	Ø 8,000	-	Ø 7,80	Ø 8,00	24,00	28,00	0,500	-	64,00	.HB
AM.TROCHO.08.24.08.R0750.01	Ø 8,000	-	Ø 7,80	Ø 8,00	24,00	28,00	0,750	-	64,00	.HB
AM.TROCHO.08.24.08.R1000.01	Ø 8,000	-	Ø 7,80	Ø 8,00	24,00	28,00	1,000	-	64,00	.HB
AM.TROCHO.9525.30.10.R0508.01	Ø 9,525	3/8"	Ø 9,20	Ø 10,00	30,00	36,00	0,508	0,02	73,00	.HB
AM.TROCHO.9525.30.10.R0762.01	Ø 9,525	3/8"	Ø 9,20	Ø 10,00	30,00	36,00	0,762	0,03	73,00	.HB
AM.TROCHO.9525.30.10.R1016.01	Ø 9,525	3/8"	Ø 9,20	Ø 10,00	30,00	36,00	1,016	0,04	73,00	.HB
AM.TROCHO.10.30.10.R0500.01	Ø 10,000	-	Ø 9,70	Ø 10,00	30,00	36,00	0,500	-	73,00	.HB
AM.TROCHO.10.30.10.R0750.01	Ø 10,000	-	Ø 9,70	Ø 10,00	30,00	36,00	0,750	-	73,00	.HB
AM.TROCHO.10.30.10.R1000.01	Ø 10,000	-	Ø 9,70	Ø 10,00	30,00	36,00	1,000	-	73,00	.HB
AM.TROCHO.10.30.10.R1250.01	Ø 10,000	-	Ø 9,70	Ø 10,00	30,00	36,00	1,250	-	73,00	.HB
AM.TROCHO.111125.34.12.R0508.01	Ø 11,1125	7/16"	Ø 10,80	Ø 12,00	34,00	38,00	0,508	0,02	84,00	.HB
AM.TROCHO.111125.34.12.R0762.01	Ø 11,1125	7/16"	Ø 10,80	Ø 12,00	34,00	38,00	0,762	0,03	84,00	.HB
AM.TROCHO.111125.34.12.R1016.01	Ø 11,1125	7/16"	Ø 10,80	Ø 12,00	34,00	38,00	1,016	0,04	84,00	.HB
AM.TROCHO.12.36.12.R0500.01	Ø 12,000	-	Ø 11,70	Ø 12,00	36,00	40,00	0,500	-	84,00	.HB
AM.TROCHO.12.36.12.R0750.01	Ø 12,000	-	Ø 11,70	Ø 12,00	36,00	40,00	0,75	-	84,00	.HB
AM.TROCHO.12.36.12.R1000.01	Ø 12,000	-	Ø 11,70	Ø 12,00	36,00	40,00	1,000	-	84,00	.HB
AM.TROCHO.12.36.12.R1250.01	Ø 12,000	-	Ø 11,70	Ø 12,00	36,00	40,00	1,250	-	84,00	.HB
AM.TROCHO.12700.38.14.R0508.01	Ø 12,700	1/2"	Ø 12,40	Ø 14,00	38,00	42,00	0,508	0,02	84,00	.HB
AM.TROCHO.12700.38.14.R0762.01	Ø 12,700	1/2"	Ø 12,40	Ø 14,00	38,00	42,00	0,762	0,03	84,00	.HB
AM.TROCHO.12700.38.14.R1016.01	Ø 12,700	1/2"	Ø 12,40	Ø 14,00	38,00	42,00	1,016	0,04	84,00	.HB
AM.TROCHO.12700.38.14.R1270.01	Ø 12,700	1/2"	Ø 12,40	Ø 14,00	38,00	42,00	1,270	0,05	84,00	.HB
AM.TROCHO.12700.38.14.R1524.01	Ø 12,700	1/2"	Ø 12,40	Ø 14,00	38,00	42,00	1,524	0,06	84,00	.HB
AM.TROCHO.14.43.24.R1000.01	Ø 14,000	-	Ø 13,70	Ø 14,00	43,00	48,00	1,000	-	84,00	.HB
AM.TROCHO.14.43.24.R1250.01	Ø 14,000	-	Ø 13,70	Ø 14,00	43,00	48,00	1,250	-	84,00	.HB
AM.TROCHO.14.43.24.R1500.01	Ø 14,000	-	Ø 13,70	Ø 14,00	43,00	48,00	1,500	-	84,00	.HB
AM.TROCHO.142875.43.16.R0762.01	Ø 14,2875	9/16"	Ø 13,90	Ø 16,00	43,00	48,00	0,762	0,03	83,00	.HB
AM.TROCHO.142875.43.16.R1016.01	Ø 14,2875	9/16"	Ø 13,90	Ø 16,00	43,00	48,00	1,016	0,04	83,00	.HB
AM.TROCHO.142875.43.16.R1270.01	Ø 14,2875	9/16"	Ø 13,90	Ø 16,00	43,00	48,00	1,270	0,05	83,00	.HB
AM.TROCHO.142875.43.16.R1524.01	Ø 14,2875	9/16"	Ø 13,90	Ø 16,00	43,00	48,00	1,524	0,06	83,00	.HB
AM.TROCHO.15875.48.16.R0762.01	Ø 15,875	5/8"	Ø 15,50	Ø 16,00	48,00	52,00	0,762	0,03	83,00	.HB
AM.TROCHO.15875.48.16.R1016.01	Ø 15,875	5/8"	Ø 15,50	Ø 16,00	48,00	52,00	1,016	0,04	83,00	.HB
AM.TROCHO.15875.48.16.R1270.01	Ø 15,875	5/8"	Ø 15,50	Ø 16,00	48,00	52,00	1,270	0,05	83,00	.HB
AM.TROCHO.15875.48.16.R1524.01	Ø 15,875	5/8"	Ø 15,50	Ø 16,00	48,00	52,00	1,524	0,06	83,00	.HB
AM.TROCHO.16.48.16.R1000.01	Ø 16,000	-	Ø 15,70	Ø 16,00	48,00	52,00	1,000	-	83,00	.HB
AM.TROCHO.16.48.16.R1250.01	Ø 16,000	-	Ø 15,70	Ø 16,00	48,00	52,00	1,250	-	83,00	.HB
AM.TROCHO.16.48.16.R1500.01	Ø 16,000	-	Ø 15,70	Ø 16,00	48,00	52,00	1,500	-	83,00	.HB

■ Für einen Fräser mit HB-Schaft ergänzen Sie „HB“ an die Artikelnummer, z. B. AM.TROCHO.04.13.06.R0200.01.HB

Ab Lager lieferbar.

2xD Alu-Trochoid Torisch

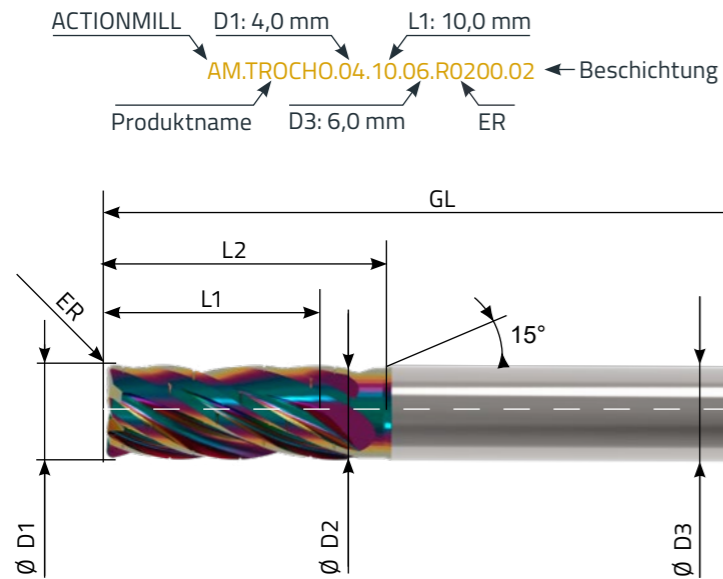
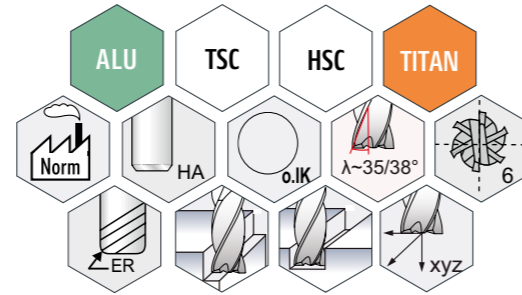

■ β-TITAN beschichtet



5x PLUS für den ACTIONMILL:

- Vibrationsfreie Bearbeitung durch ungleiche Teilung
- Spezielle Schneidkantenausführung zur Schwingungsdämpfung
- Innere Kühlschmierstoff-Zufuhr, Y-Austritt
- Spanteilergeometrie zum prozesssicheren Schrappen von Taschen und Konturen
- Eckenradien stabilisieren den Fräser zusätzlich

Artikelnummer	D1 (mm)	D1 (inch)	D2 (mm)	D3 h6 (mm)	L1 (mm)	L2 (mm)	ER (mm)	ER (inch)	GL (mm)	HB-Schaft
AM.TROCHO.03968.10.06.R0254.02	Ø 3,968	Ø 5/32"	Ø 3,80	Ø 6,00	10,00	18,00	0,254	0,01	58,00	.HB
AM.TROCHO.04.10.06.R0200.02	Ø 4,000	-	Ø 3,80	Ø 6,00	10,00	18,00	0,200	-	58,00	.HB
AM.TROCHO.04.10.06.R0300.02	Ø 4,000	-	Ø 3,80	Ø 6,00	10,00	18,00	0,300	-	58,00	.HB
AM.TROCHO.04762.14.06.R0254.02	Ø 4,762	Ø 3/16"	Ø 4,50	Ø 6,00	14,00	20,00	0,254	0,01	58,00	.HB
AM.TROCHO.05.14.06.R0200.02	Ø 5,000	-	Ø 4,80	Ø 6,00	14,00	20,00	0,200	-	58,00	.HB
AM.TROCHO.05.14.06.R0300.02	Ø 5,000	-	Ø 4,80	Ø 6,00	14,00	20,00	0,300	-	58,00	.HB
AM.TROCHO.05556.14.06.R0254.02	Ø 5,556	Ø 7/32"	Ø 5,20	Ø 6,00	14,00	22,00	0,254	0,01	58,00	.HB
AM.TROCHO.06.14.06.R0200.02	Ø 6,000	-	Ø 5,70	Ø 6,00	14,00	22,00	0,200	-	58,00	.HB
AM.TROCHO.06.14.06.R0300.02	Ø 6,000	-	Ø 5,70	Ø 6,00	14,00	22,00	0,300	-	58,00	.HB
AM.TROCHO.06.14.06.R0500.02	Ø 6,000	-	Ø 5,70	Ø 6,00	14,00	22,00	0,500	-	58,00	.HB
AM.TROCHO.0635.14.08.R0254.02	Ø 6,350	Ø 1/4"	Ø 6,00	Ø 8,00	14,00	22,00	0,254	0,01	64,00	.HB
AM.TROCHO.0635.14.08.R0508.02	Ø 6,350	Ø 1/4"	Ø 6,00	Ø 8,00	14,00	22,00	0,508	0,02	64,00	.HB
AM.TROCHO.7144.18.08.R0254.02	Ø 7,144	Ø 9/32"	Ø 6,90	Ø 8,00	18,00	26,00	0,254	0,01	64,00	.HB
AM.TROCHO.7144.18.08.R0508.02	Ø 7,144	Ø 9/32"	Ø 6,90	Ø 8,00	18,00	26,00	0,508	0,02	64,00	.HB
AM.TROCHO.7144.18.08.R0762.02	Ø 7,144	Ø 9/32"	Ø 6,90	Ø 8,00	18,00	26,00	0,762	0,03	64,00	.HB
AM.TROCHO.7938.18.08.R0254.02	Ø 7,938	Ø 5/16"	Ø 7,80	Ø 8,00	18,00	26,00	0,254	0,01	64,00	.HB
AM.TROCHO.7938.18.08.R0508.02	Ø 7,938	Ø 5/16"	Ø 7,80	Ø 8,00	18,00	26,00	0,508	0,02	64,00	.HB
AM.TROCHO.7938.18.08.R0762.02	Ø 7,938	Ø 5/16"	Ø 7,80	Ø 8,00	18,00	26,00	0,762	0,03	64,00	.HB
AM.TROCHO.08.18.08.R0500.02	Ø 8,000	-	Ø 7,80	Ø 8,00	18,00	26,00	0,500	-	64,00	.HB
AM.TROCHO.08.18.08.R0750.02	Ø 8,000	-	Ø 7,80	Ø 8,00	18,00	26,00	0,750	-	64,00	.HB
AM.TROCHO.08.18.08.R1000.02	Ø 8,000	-	Ø 7,80	Ø 8,00	18,00	26,00	1,000	-	64,00	.HB
AM.TROCHO.9525.22.10.R0508.02	Ø 9,525	Ø 3/8"	Ø 9,20	Ø 10,00	22,00	32,00	0,508	0,02	73,00	.HB
AM.TROCHO.9525.22.10.R0762.02	Ø 9,525	Ø 3/8"	Ø 9,20	Ø 10,00	22,00	32,00	0,762	0,03	73,00	.HB
AM.TROCHO.9525.22.10.R1016.02	Ø 9,525	Ø 3/8"	Ø 9,20	Ø 10,00	22,00	32,00	1,016	0,04	73,00	.HB
AM.TROCHO.10.22.10.R0500.02	Ø 10,000	-	Ø 9,70	Ø 10,00	22,00	32,00	0,500	-	73,00	.HB
AM.TROCHO.10.22.10.R0750.02	Ø 10,000	-	Ø 9,70	Ø 10,00	22,00	32,00	0,750	-	73,00	.HB
AM.TROCHO.10.22.10.R1000.02	Ø 10,000	-	Ø 9,70	Ø 10,00	22,00	32,00	1,000	-	73,00	.HB
AM.TROCHO.10.22.10.R1250.02	Ø 10,000	-	Ø 9,70	Ø 10,00	22,00	32,00	1,250	-	73,00	.HB
AM.TROCHO.111125.26.12.R0508.02	Ø 11,1125	Ø 7/16"	Ø 10,80	Ø 12,00	26,00	36,00	0,508	0,02	84,00	.HB
AM.TROCHO.111125.26.12.R0762.02	Ø 11,1125	Ø 7/16"	Ø 10,80	Ø 12,00	26,00	36,00	0,762	0,03	84,00	.HB
AM.TROCHO.111125.26.12.R1016.02	Ø 11,1125	Ø 7/16"	Ø 10,80	Ø 12,00	26,00	36,00	1,016	0,04	84,00	.HB
AM.TROCHO.12.26.12.R0500.02	Ø 12,000	-	Ø 11,70	Ø 12,00	26,00	36,00	0,500	-	84,00	.HB
AM.TROCHO.12.26.12.R0750.02	Ø 12,000	-	Ø 11,70	Ø 12,00	26,00	36,00	0,750	-	84,00	.HB
AM.TROCHO.12.26.12.R1000.02	Ø 12,000	-	Ø 11,70	Ø 12,00	26,00	36,00	1,000	-	84,00	.HB
AM.TROCHO.12.26.12.R1250.02	Ø 12,000	-	Ø 11,70	Ø 12,00	26,00	36,00	1,250	-	84,00	.HB
AM.TROCHO.12700.26.14.R0508.02	Ø 12,700	Ø 1/2"	Ø 12,40	Ø 14,00	28,00	36,00	0,508	0,02	84,00	.HB
AM.TROCHO.12700.26.14.R0762.02	Ø 12,700	Ø 1/2"	Ø 12,40	Ø 14,00	28,00	36,00	0,762	0,03	84,00	.HB
AM.TROCHO.12700.26.14.R1016.02	Ø 12,700	Ø 1/2"	Ø 12,40	Ø 14,00	28,00	36,00	1,016	0,04	84,00	.HB
AM.TROCHO.12700.26.14.R1270.02	Ø 12,700	Ø 1/2"	Ø 12,40	Ø 14,00	28,00	36,00	1,270	0,05	84,00	.HB
AM.TROCHO.12700.26.14.R1524.02	Ø 12,700	Ø 1/2"	Ø 12,40	Ø 14,00	28,00	36,00	1,524	0,06	84,00	.HB
AM.TROCHO.14.28.24.R1000.02	Ø 14,000	-	Ø 13,70	Ø 14,00	31,00	40,00	1,000	-	84,00	.HB
AM.TROCHO.14.28.24.R1250.02	Ø 14,000	-	Ø 13,70	Ø 14,00	31,00	40,00	1,250	-	84,00	.HB
AM.TROCHO.14.28.24.R1500.02	Ø 14,000	-	Ø 13,70	Ø 14,00	31,00	40,00	1,500	-	84,00	.HB
AM.TROCHO.142875.29.16.R0762.02	Ø 14,2875	Ø 9/16"	Ø 13,90	Ø 16,00	32,00	40,00	0,762	0,03	83,00	.HB
AM.TROCHO.142875.29.16.R1016.02	Ø 14,2875	Ø 9/16"	Ø 13,90	Ø 16,00	32,00	40,00	1,016	0,04	83,00	.HB
AM.TROCHO.142875.29.16.R1270.02	Ø 14,2875	Ø 9/16"	Ø 13,90	Ø 16,00	32,00	40,00	1,270	0,05	83,00	.HB
AM.TROCHO.142875.29.16.R1524.02	Ø 14,2875	Ø 9/16"	Ø 13,90	Ø 16,00	32,00	40,00	1,524	0,06	83,00	.HB
AM.TROCHO.15875.32.16.R0762.02	Ø 15,875	Ø 5/8"	Ø 15,50	Ø 16,00	35,00	43,00	0,762	0,03	83,00	.HB
AM.TROCHO.15875.32.16.R1016.02	Ø 15,875	Ø 5/8"	Ø 15,50	Ø 16,00	35,00	43,00	1,016	0,04	83,00	.HB
AM.TROCHO.15875.32.16.R1270.02	Ø 15,875	Ø 5/8"	Ø 15,50	Ø 16,00	35,00	43,00	1,270	0,05	83,00	.HB
AM.TROCHO.15875.32.16.R1524.02	Ø 15,875	Ø 5/8"	Ø 15,50	Ø 16,00	35,00	43,00	1,524	0,06	83,00	.HB
AM.TROCHO.16.32.16.R1000.02	Ø 16,000	-	Ø 15,70	Ø 16,00	35,00	43,00	1,000	-	83,00	.HB
AM.TROCHO.16.32.16.R1250.02	Ø 16,000	-	Ø 15,70	Ø 16,00	35,00	43,00	1,250	-	83,00	.HB
AM.TROCHO.16.32.16.R1500.02	Ø 16,000	-	Ø 15,70	Ø 16,00	35,00	43,00	1,500	-	83,00	.HB

■ Für einen Fräser mit HB-Schaft ergänzen Sie „HB“ an die Artikelnummer, z. B. AM.TROCHO.04.10.06.R0200.02.HB

Ab Lager lieferbar.

3xD Alu-Trochoid Torisch

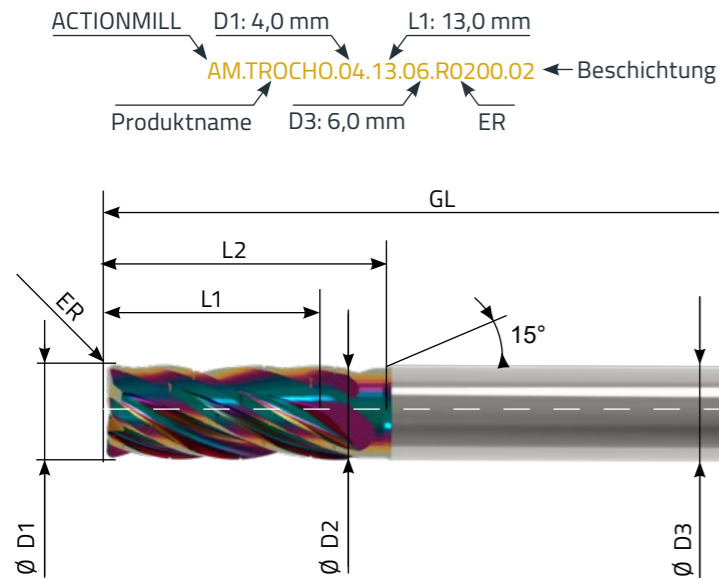
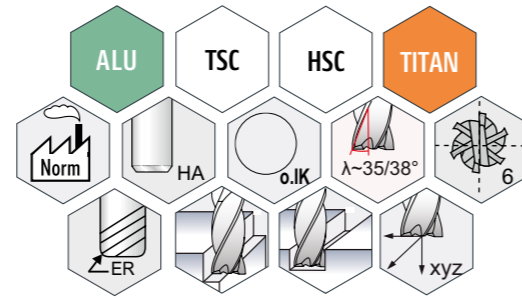

■ β-TITAN beschichtet



5x PLUS für den ACTIONMILL:

- Vibrationsfreie Bearbeitung durch ungleiche Teilung
- Spezielle Schneidkantenausführung zur Schwingungsdämpfung
- Innere Kühlschmierstoff-Zufuhr, Y-Austritt
- Spanteilergeometrie zum prozesssicheren Schrappen von Taschen und Konturen
- Eckenradien stabilisieren den Fräser zusätzlich

Artikelnummer	D1 (mm)	D1 (inch)	D2 (mm)	D3 h6 (mm)	L1 (mm)	L2 (mm)	ER (mm)	ER (inch)	GL (mm)	HB-Schaft
AM.TROCHO.03968.13.06.R0254.02	Ø 3,968	5/32"	Ø 3,80	Ø 6,00	13,00	18,00	0,254	0,01	58,00	.HB
AM.TROCHO.04.13.06.R0200.02	Ø 4,000	-	Ø 3,80	Ø 6,00	13,00	18,00	0,200	-	58,00	.HB
AM.TROCHO.04.13.06.R0300.02	Ø 4,000	-	Ø 3,80	Ø 6,00	13,00	18,00	0,300	-	58,00	.HB
AM.TROCHO.04762.15.06.R0254.02	Ø 4,762	3/16"	Ø 4,50	Ø 6,00	15,00	20,00	0,254	0,01	58,00	.HB
AM.TROCHO.05.15.06.R0200.02	Ø 5,000	-	Ø 4,80	Ø 6,00	15,00	20,00	0,200	-	58,00	.HB
AM.TROCHO.05.15.06.R0300.02	Ø 5,000	-	Ø 4,80	Ø 6,00	15,00	20,00	0,300	-	58,00	.HB
AM.TROCHO.05556.18.06.R0254.02	Ø 5,556	7/32"	Ø 5,20	Ø 6,00	18,00	22,00	0,254	0,01	58,00	.HB
AM.TROCHO.06.18.06.R0200.02	Ø 6,000	-	Ø 5,70	Ø 6,00	18,00	22,00	0,200	-	58,00	.HB
AM.TROCHO.06.18.06.R0300.02	Ø 6,000	-	Ø 5,70	Ø 6,00	18,00	22,00	0,300	-	58,00	.HB
AM.TROCHO.06.18.06.R0500.02	Ø 6,000	-	Ø 5,70	Ø 6,00	18,00	22,00	0,500	-	58,00	.HB
AM.TROCHO.0635.20.08.R0254.02	Ø 6,350	1/4"	Ø 6,00	Ø 8,00	20,00	24,00	0,254	0,01	64,00	.HB
AM.TROCHO.0635.20.08.R0508.02	Ø 6,350	1/4"	Ø 6,00	Ø 8,00	20,00	24,00	0,508	0,02	64,00	.HB
AM.TROCHO.7144.22.08.R0254.02	Ø 7,144	9/32"	Ø 6,90	Ø 8,00	22,00	26,00	0,254	0,01	64,00	.HB
AM.TROCHO.7144.22.08.R0508.02	Ø 7,144	9/32"	Ø 6,90	Ø 8,00	22,00	26,00	0,508	0,02	64,00	.HB
AM.TROCHO.7144.22.08.R0762.02	Ø 7,144	9/32"	Ø 6,90	Ø 8,00	22,00	26,00	0,762	0,03	64,00	.HB
AM.TROCHO.7938.24.08.R0254.02	Ø 7,938	5/16"	Ø 7,80	Ø 8,00	24,00	28,00	0,254	0,01	64,00	.HB
AM.TROCHO.7938.24.08.R0508.02	Ø 7,938	5/16"	Ø 7,80	Ø 8,00	24,00	28,00	0,508	0,02	64,00	.HB
AM.TROCHO.7938.24.08.R0762.02	Ø 7,938	5/16"	Ø 7,80	Ø 8,00	24,00	28,00	0,762	0,03	64,00	.HB
AM.TROCHO.08.24.08.R0500.02	Ø 8,000	-	Ø 7,80	Ø 8,00	24,00	28,00	0,500	-	64,00	.HB
AM.TROCHO.08.24.08.R0750.02	Ø 8,000	-	Ø 7,80	Ø 8,00	24,00	28,00	0,750	-	64,00	.HB
AM.TROCHO.08.24.08.R1000.02	Ø 8,000	-	Ø 7,80	Ø 8,00	24,00	28,00	1,000	-	64,00	.HB
AM.TROCHO.9525.30.10.R0508.02	Ø 9,525	3/8"	Ø 9,20	Ø 10,00	30,00	36,00	0,508	0,02	73,00	.HB
AM.TROCHO.9525.30.10.R0762.02	Ø 9,525	3/8"	Ø 9,20	Ø 10,00	30,00	36,00	0,762	0,03	73,00	.HB
AM.TROCHO.9525.30.10.R1016.02	Ø 9,525	3/8"	Ø 9,20	Ø 10,00	30,00	36,00	1,016	0,04	73,00	.HB
AM.TROCHO.10.30.10.R0500.02	Ø 10,000	-	Ø 9,70	Ø 10,00	30,00	36,00	0,500	-	73,00	.HB
AM.TROCHO.10.30.10.R0750.02	Ø 10,000	-	Ø 9,70	Ø 10,00	30,00	36,00	0,750	-	73,00	.HB
AM.TROCHO.10.30.10.R1000.02	Ø 10,000	-	Ø 9,70	Ø 10,00	30,00	36,00	1,000	-	73,00	.HB
AM.TROCHO.10.30.10.R1250.02	Ø 10,000	-	Ø 9,70	Ø 10,00	30,00	36,00	1,250	-	73,00	.HB
AM.TROCHO.111125.34.12.R0508.02	Ø 11,1125	7/16"	Ø 10,80	Ø 12,00	34,00	38,00	0,508	0,02	84,00	.HB
AM.TROCHO.111125.34.12.R0762.02	Ø 11,1125	7/16"	Ø 10,80	Ø 12,00	34,00	38,00	0,762	0,03	84,00	.HB
AM.TROCHO.111125.34.12.R1016.02	Ø 11,1125	7/16"	Ø 10,80	Ø 12,00	34,00	38,00	1,016	0,04	84,00	.HB
AM.TROCHO.12.36.12.R0500.02	Ø 12,000	-	Ø 11,70	Ø 12,00	36,00	40,00	0,500	-	84,00	.HB
AM.TROCHO.12.36.12.R0750.02	Ø 12,000	-	Ø 11,70	Ø 12,00	36,00	40,00	0,75	-	84,00	.HB
AM.TROCHO.12.36.12.R1000.02	Ø 12,000	-	Ø 11,70	Ø 12,00	36,00	40,00	1,000	-	84,00	.HB
AM.TROCHO.12.36.12.R1250.02	Ø 12,000	-	Ø 11,70	Ø 12,00	36,00	40,00	1,250	-	84,00	.HB
AM.TROCHO.12700.38.14.R0508.02	Ø 12,700	1/2"	Ø 12,40	Ø 14,00	38,00	42,00	0,508	0,02	84,00	.HB
AM.TROCHO.12700.38.14.R0762.02	Ø 12,700	1/2"	Ø 12,40	Ø 14,00	38,00	42,00	0,762	0,03	84,00	.HB
AM.TROCHO.12700.38.14.R1016.02	Ø 12,700	1/2"	Ø 12,40	Ø 14,00	38,00	42,00	1,016	0,04	84,00	.HB
AM.TROCHO.12700.38.14.R1270.02	Ø 12,700	1/2"	Ø 12,40	Ø 14,00	38,00	42,00	1,270	0,05	84,00	.HB
AM.TROCHO.12700.38.14.R1524.02	Ø 12,700	1/2"	Ø 12,40	Ø 14,00	38,00	42,00	1,524	0,06	84,00	.HB
AM.TROCHO.14.43.24.R1000.02	Ø 14,000	-	Ø 13,70	Ø 14,00	43,00	48,00	1,000	-	84,00	.HB
AM.TROCHO.14.43.24.R1250.02	Ø 14,000	-	Ø 13,70	Ø 14,00	43,00	48,00	1,250	-	84,00	.HB
AM.TROCHO.14.43.24.R1500.02	Ø 14,000	-	Ø 13,70	Ø 14,00	43,00	48,00	1,500	-	84,00	.HB
AM.TROCHO.142875.43.16.R0762.02	Ø 14,2875	9/16"	Ø 13,90	Ø 16,00	43,00	48,00	0,762	0,03	83,00	.HB
AM.TROCHO.142875.43.16.R1016.02	Ø 14,2875	9/16"	Ø 13,90	Ø 16,00	43,00	48,00	1,016	0,04	83,00	.HB
AM.TROCHO.142875.43.16.R1270.02	Ø 14,2875	9/16"	Ø 13,90	Ø 16,00	43,00	48,00	1,270	0,05	83,00	.HB
AM.TROCHO.142875.43.16.R1524.02	Ø 14,2875	9/16"	Ø 13,90	Ø 16,00	43,00	48,00	1,524	0,06	83,00	.HB
AM.TROCHO.15875.48.16.R0762.02	Ø 15,875	5/8"	Ø 15,50	Ø 16,00	48,00	52,00	0,762	0,03	83,00	.HB
AM.TROCHO.15875.48.16.R1016.02	Ø 15,875	5/8"	Ø 15,50	Ø 16,00	48,00	52,00	1,016	0,04	83,00	.HB
AM.TROCHO.15875.48.16.R1270.02	Ø 15,875	5/8"	Ø 15,50	Ø 16,00	48,00	52,00	1,270	0,05	83,00	.HB
AM.TROCHO.15875.48.16.R1524.02	Ø 15,875	5/8"	Ø 15,50	Ø 16,00	48,00	52,00	1,524	0,06	83,00	.HB
AM.TROCHO.16.48.16.R1000.02	Ø 16,000	-	Ø 15,70	Ø 16,00	48,00	52,00	1,000	-	83,00	.HB
AM.TROCHO.16.48.16.R1250.02	Ø 16,000	-	Ø 15,70	Ø 16,00	48,00	52,00	1,250	-	83,00	.HB
AM.TROCHO.16.48.16.R1500.02	Ø 16,000	-	Ø 15,70	Ø 16,00	48,00	52,00	1,500	-	83,00	.HB

■ Für einen Fräser mit HB-Schaft ergänzen Sie „HB“ an die Artikelnummer, z. B. AM.TROCHO.04.13.06.R0200.02.HB

Ab Lager lieferbar.

2xD Steel-Trochoid Torisch

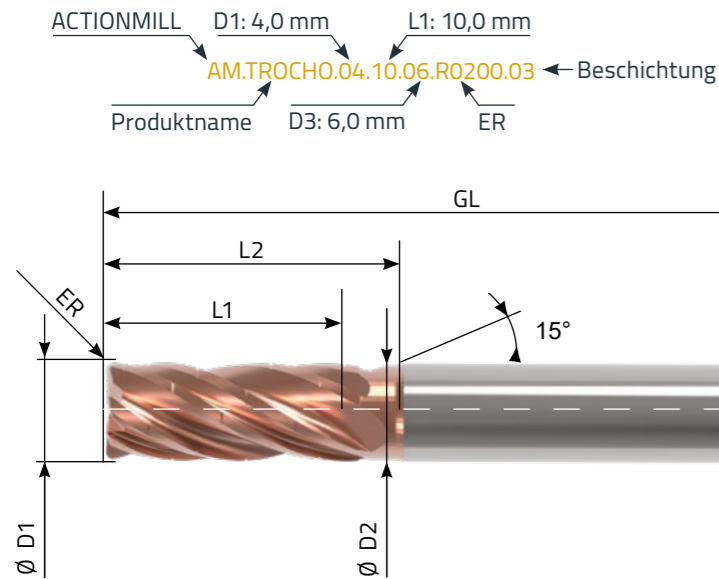
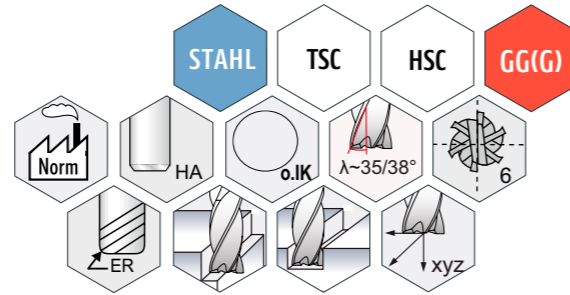

■ γ-Steel beschichtet



5x PLUS für den ACTIONMILL:

- Vibrationsfreie Bearbeitung durch ungleiche Teilung
- Spezielle Schneidkantenausführung zur Schwingungsdämpfung
- Innere Kühlschmierstoff-Zufuhr, Y-Austritt
- Spanteilergometrie zum prozesssicheren Schrappen von Taschen und Konturen
- Eckenradien stabilisieren den Fräser zusätzlich

Artikelnummer	D1 (mm)	D1 (inch)	D2 (mm)	D3 h6 (mm)	L1 (mm)	L2 (mm)	ER (mm)	ER (inch)	GL (mm)	HB-Schaft
AM.TROCHO.03968.10.06.R0254.03	Ø 3,968	Ø 5/32"	Ø 3,80	Ø 6,00	10,00	18,00	0,254	0,01	58,00	.HB
AM.TROCHO.04.10.06.R0200.03	Ø 4,000	-	Ø 3,80	Ø 6,00	10,00	18,00	0,200	-	58,00	.HB
AM.TROCHO.04.10.06.R0300.03	Ø 4,000	-	Ø 3,80	Ø 6,00	10,00	18,00	0,300	-	58,00	.HB
AM.TROCHO.04762.14.06.R0254.03	Ø 4,762	Ø 3/16"	Ø 4,50	Ø 6,00	14,00	20,00	0,254	0,01	58,00	.HB
AM.TROCHO.05.14.06.R0200.03	Ø 5,000	-	Ø 4,80	Ø 6,00	14,00	20,00	0,200	-	58,00	.HB
AM.TROCHO.05.14.06.R0300.03	Ø 5,000	-	Ø 4,80	Ø 6,00	14,00	20,00	0,300	-	58,00	.HB
AM.TROCHO.05556.14.06.R0254.03	Ø 5,556	Ø 7/32"	Ø 5,20	Ø 6,00	14,00	22,00	0,254	0,01	58,00	.HB
AM.TROCHO.06.14.06.R0200.03	Ø 6,000	-	Ø 5,70	Ø 6,00	14,00	22,00	0,200	-	58,00	.HB
AM.TROCHO.06.14.06.R0300.03	Ø 6,000	-	Ø 5,70	Ø 6,00	14,00	22,00	0,300	-	58,00	.HB
AM.TROCHO.06.14.06.R0500.03	Ø 6,000	-	Ø 5,70	Ø 6,00	14,00	22,00	0,500	-	58,00	.HB
AM.TROCHO.0635.14.08.R0254.03	Ø 6,350	Ø 1/4"	Ø 6,00	Ø 8,00	14,00	22,00	0,254	0,01	64,00	.HB
AM.TROCHO.0635.14.08.R0508.03	Ø 6,350	Ø 1/4"	Ø 6,00	Ø 8,00	14,00	22,00	0,508	0,02	64,00	.HB
AM.TROCHO.7144.18.08.R0254.03	Ø 7,144	Ø 9/32"	Ø 6,90	Ø 8,00	18,00	26,00	0,254	0,01	64,00	.HB
AM.TROCHO.7144.18.08.R0508.03	Ø 7,144	Ø 9/32"	Ø 6,90	Ø 8,00	18,00	26,00	0,508	0,02	64,00	.HB
AM.TROCHO.7144.18.08.R0762.03	Ø 7,144	Ø 9/32"	Ø 6,90	Ø 8,00	18,00	26,00	0,762	0,03	64,00	.HB
AM.TROCHO.7938.18.08.R0254.03	Ø 7,938	Ø 5/16"	Ø 7,80	Ø 8,00	18,00	26,00	0,254	0,01	64,00	.HB
AM.TROCHO.7938.18.08.R0508.03	Ø 7,938	Ø 5/16"	Ø 7,80	Ø 8,00	18,00	26,00	0,508	0,02	64,00	.HB
AM.TROCHO.7938.18.08.R0762.03	Ø 7,938	Ø 5/16"	Ø 7,80	Ø 8,00	18,00	26,00	0,762	0,03	64,00	.HB
AM.TROCHO.08.18.08.R0500.03	Ø 8,000	-	Ø 7,80	Ø 8,00	18,00	26,00	0,500	-	64,00	.HB
AM.TROCHO.08.18.08.R0750.03	Ø 8,000	-	Ø 7,80	Ø 8,00	18,00	26,00	0,750	-	64,00	.HB
AM.TROCHO.08.18.08.R1000.03	Ø 8,000	-	Ø 7,80	Ø 8,00	18,00	26,00	1,000	-	64,00	.HB
AM.TROCHO.9525.22.10.R0508.03	Ø 9,525	Ø 3/8"	Ø 9,20	Ø 10,00	22,00	32,00	0,508	0,02	73,00	.HB
AM.TROCHO.9525.22.10.R0762.03	Ø 9,525	Ø 3/8"	Ø 9,20	Ø 10,00	22,00	32,00	0,762	0,03	73,00	.HB
AM.TROCHO.9525.22.10.R1016.03	Ø 9,525	Ø 3/8"	Ø 9,20	Ø 10,00	22,00	32,00	1,016	0,04	73,00	.HB
AM.TROCHO.10.22.10.R0500.03	Ø 10,000	-	Ø 9,70	Ø 10,00	22,00	32,00	0,500	-	73,00	.HB
AM.TROCHO.10.22.10.R0750.03	Ø 10,000	-	Ø 9,70	Ø 10,00	22,00	32,00	0,750	-	73,00	.HB
AM.TROCHO.10.22.10.R1000.03	Ø 10,000	-	Ø 9,70	Ø 10,00	22,00	32,00	1,000	-	73,00	.HB
AM.TROCHO.10.22.10.R1250.03	Ø 10,000	-	Ø 9,70	Ø 10,00	22,00	32,00	1,250	-	73,00	.HB
AM.TROCHO.111125.26.12.R0508.03	Ø 11,1125	Ø 7/16"	Ø 10,80	Ø 12,00	26,00	36,00	0,508	0,02	84,00	.HB
AM.TROCHO.111125.26.12.R0762.03	Ø 11,1125	Ø 7/16"	Ø 10,80	Ø 12,00	26,00	36,00	0,762	0,03	84,00	.HB
AM.TROCHO.111125.26.12.R1016.03	Ø 11,1125	Ø 7/16"	Ø 10,80	Ø 12,00	26,00	36,00	1,016	0,04	84,00	.HB
AM.TROCHO.12.26.12.R0500.03	Ø 12,000	-	Ø 11,70	Ø 12,00	26,00	36,00	0,500	-	84,00	.HB
AM.TROCHO.12.26.12.R0750.03	Ø 12,000	-	Ø 11,70	Ø 12,00	26,00	36,00	0,750	-	84,00	.HB
AM.TROCHO.12.26.12.R1000.03	Ø 12,000	-	Ø 11,70	Ø 12,00	26,00	36,00	1,000	-	84,00	.HB
AM.TROCHO.12.26.12.R1250.03	Ø 12,000	-	Ø 11,70	Ø 12,00	26,00	36,00	1,250	-	84,00	.HB
AM.TROCHO.12700.26.14.R0508.03	Ø 12,700	Ø 1/2"	Ø 12,40	Ø 14,00	28,00	36,00	0,508	0,02	84,00	.HB
AM.TROCHO.12700.26.14.R0762.03	Ø 12,700	Ø 1/2"	Ø 12,40	Ø 14,00	28,00	36,00	0,762	0,03	84,00	.HB
AM.TROCHO.12700.26.14.R1016.03	Ø 12,700	Ø 1/2"	Ø 12,40	Ø 14,00	28,00	36,00	1,016	0,04	84,00	.HB
AM.TROCHO.12700.26.14.R1270.03	Ø 12,700	Ø 1/2"	Ø 12,40	Ø 14,00	28,00	36,00	1,270	0,05	84,00	.HB
AM.TROCHO.12700.26.14.R1524.03	Ø 12,700	Ø 1/2"	Ø 12,40	Ø 14,00	28,00	36,00	1,524	0,06	84,00	.HB
AM.TROCHO.14.28.24.R1000.03	Ø 14,000	-	Ø 13,70	Ø 14,00	31,00	40,00	1,000	-	84,00	.HB
AM.TROCHO.14.28.24.R1250.03	Ø 14,000	-	Ø 13,70	Ø 14,00	31,00	40,00	1,250	-	84,00	.HB
AM.TROCHO.14.28.24.R1500.03	Ø 14,000	-	Ø 13,70	Ø 14,00	31,00	40,00	1,500	-	84,00	.HB
AM.TROCHO.142875.29.16.R0762.03	Ø 14,2875	Ø 9/16"	Ø 13,90	Ø 16,00	32,00	40,00	0,762	0,03	83,00	.HB
AM.TROCHO.142875.29.16.R1016.03	Ø 14,2875	Ø 9/16"	Ø 13,90	Ø 16,00	32,00	40,00	1,016	0,04	83,00	.HB
AM.TROCHO.142875.29.16.R1270.03	Ø 14,2875	Ø 9/16"	Ø 13,90	Ø 16,00	32,00	40,00	1,270	0,05	83,00	.HB
AM.TROCHO.142875.29.16.R1524.03	Ø 14,2875	Ø 9/16"	Ø 13,90	Ø 16,00	32,00	40,00	1,524	0,06	83,00	.HB
AM.TROCHO.15875.32.16.R0762.03	Ø 15,875	Ø 5/8"	Ø 15,50	Ø 16,00	35,00	43,00	0,762	0,03	83,00	.HB
AM.TROCHO.15875.32.16.R1016.03	Ø 15,875	Ø 5/8"	Ø 15,50	Ø 16,00	35,00	43,00	1,016	0,04	83,00	.HB
AM.TROCHO.15875.32.16.R1270.03	Ø 15,875	Ø 5/8"	Ø 15,50	Ø 16,00	35,00	43,00	1,270	0,05	83,00	.HB
AM.TROCHO.15875.32.16.R1524.03	Ø 15,875	Ø 5/8"	Ø 15,50	Ø 16,00	35,00	43,00	1,524	0,06	83,00	.HB
AM.TROCHO.16.32.16.R1000.03	Ø 16,000	-	Ø 15,70	Ø 16,00	35,00	43,00	1,000	-	83,00	.HB
AM.TROCHO.16.32.16.R1250.03	Ø 16,000	-	Ø 15,70	Ø 16,00	35,00	43,00	1,250	-	83,00	.HB
AM.TROCHO.16.32.16.R1500.03	Ø 16,000	-	Ø 15,70	Ø 16,00	35,00	43,00	1,500	-	83,00	.HB

■ Für einen Fräser mit HB-Schaft ergänzen Sie „HB“ an die Artikelnummer, z. B. AM.TROCHO.04.10.06.R0200.03.HB

Ab Lager lieferbar.

3xD Steel-Trochoid Torisch

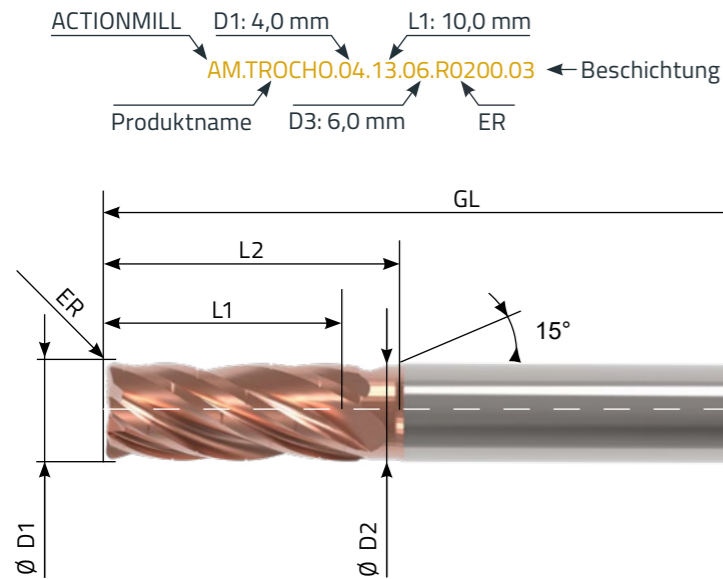
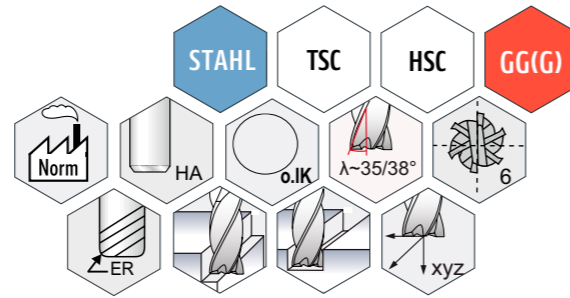

■ γ-Steel beschichtet



5x PLUS für den ACTIONMILL:



- Vibrationsfreie Bearbeitung durch ungleiche Teilung
- Spezielle Schneidkantenausführung zur Schwingungsdämpfung
- Innere Kühlschmierstoff-Zufuhr, Y-Austritt
- Spanteilergeometrie zum prozesssicheren Schrappen von Taschen und Konturen
- Eckenradien stabilisieren den Fräser zusätzlich

Artikelnummer	D1 (mm)	D1 (inch)	D2 (mm)	D3 h6 (mm)	L1 (mm)	L2 (mm)	ER (mm)	ER (inch)	GL (mm)	HB-Schaft
AM.TROCHO.03968.13.06.R0254.03	Ø 3,968	5/32"	Ø 3,80	Ø 6,00	13,00	18,00	0,254	0,01	58,00	.HB
AM.TROCHO.04.13.06.R0200.03	Ø 4,000	-	Ø 3,80	Ø 6,00	13,00	18,00	0,200	-	58,00	.HB
AM.TROCHO.04.13.06.R0300.03	Ø 4,000	-	Ø 3,80	Ø 6,00	13,00	18,00	0,300	-	58,00	.HB
AM.TROCHO.04762.15.06.R0254.03	Ø 4,762	3/16"	Ø 4,50	Ø 6,00	15,00	20,00	0,254	0,01	58,00	.HB
AM.TROCHO.05.15.06.R0200.03	Ø 5,000	-	Ø 4,80	Ø 6,00	15,00	20,00	0,200	-	58,00	.HB
AM.TROCHO.05.15.06.R0300.03	Ø 5,000	-	Ø 4,80	Ø 6,00	15,00	20,00	0,300	-	58,00	.HB
AM.TROCHO.05556.18.06.R0254.03	Ø 5,556	7/32"	Ø 5,20	Ø 6,00	18,00	22,00	0,254	0,01	58,00	.HB
AM.TROCHO.06.18.06.R0200.03	Ø 6,000	-	Ø 5,70	Ø 6,00	18,00	22,00	0,200	-	58,00	.HB
AM.TROCHO.06.18.06.R0300.03	Ø 6,000	-	Ø 5,70	Ø 6,00	18,00	22,00	0,300	-	58,00	.HB
AM.TROCHO.06.18.06.R0500.03	Ø 6,000	-	Ø 5,70	Ø 6,00	18,00	22,00	0,500	-	58,00	.HB
AM.TROCHO.0635.20.08.R0254.03	Ø 6,350	1/4"	Ø 6,00	Ø 8,00	20,00	24,00	0,254	0,01	64,00	.HB
AM.TROCHO.0635.20.08.R0508.03	Ø 6,350	1/4"	Ø 6,00	Ø 8,00	20,00	24,00	0,508	0,02	64,00	.HB
AM.TROCHO.7144.22.08.R0254.03	Ø 7,144	9/32"	Ø 6,90	Ø 8,00	22,00	26,00	0,254	0,01	64,00	.HB
AM.TROCHO.7144.22.08.R0508.03	Ø 7,144	9/32"	Ø 6,90	Ø 8,00	22,00	26,00	0,508	0,02	64,00	.HB
AM.TROCHO.7144.22.08.R0762.03	Ø 7,144	9/32"	Ø 6,90	Ø 8,00	22,00	26,00	0,762	0,03	64,00	.HB
AM.TROCHO.7938.24.08.R0254.03	Ø 7,938	5/16"	Ø 7,80	Ø 8,00	24,00	28,00	0,254	0,01	64,00	.HB
AM.TROCHO.7938.24.08.R0508.03	Ø 7,938	5/16"	Ø 7,80	Ø 8,00	24,00	28,00	0,508	0,02	64,00	.HB
AM.TROCHO.7938.24.08.R0762.03	Ø 7,938	5/16"	Ø 7,80	Ø 8,00	24,00	28,00	0,762	0,03	64,00	.HB
AM.TROCHO.08.24.08.R0500.03	Ø 8,000	-	Ø 7,80	Ø 8,00	24,00	28,00	0,500	-	64,00	.HB
AM.TROCHO.08.24.08.R0750.03	Ø 8,000	-	Ø 7,80	Ø 8,00	24,00	28,00	0,750	-	64,00	.HB
AM.TROCHO.08.24.08.R1000.03	Ø 8,000	-	Ø 7,80	Ø 8,00	24,00	28,00	1,000	-	64,00	.HB
AM.TROCHO.9525.30.10.R0508.03	Ø 9,525	3/8"	Ø 9,20	Ø 10,00	30,00	36,00	0,508	0,02	73,00	.HB
AM.TROCHO.9525.30.10.R0762.03	Ø 9,525	3/8"	Ø 9,20	Ø 10,00	30,00	36,00	0,762	0,03	73,00	.HB
AM.TROCHO.9525.30.10.R1016.03	Ø 9,525	3/8"	Ø 9,20	Ø 10,00	30,00	36,00	1,016	0,04	73,00	.HB
AM.TROCHO.10.30.10.R0500.03	Ø 10,000	-	Ø 9,70	Ø 10,00	30,00	36,00	0,500	-	73,00	.HB
AM.TROCHO.10.30.10.R0750.03	Ø 10,000	-	Ø 9,70	Ø 10,00	30,00	36,00	0,750	-	73,00	.HB
AM.TROCHO.10.30.10.R1000.03	Ø 10,000	-	Ø 9,70	Ø 10,00	30,00	36,00	1,000	-	73,00	.HB
AM.TROCHO.10.30.10.R1250.03	Ø 10,000	-	Ø 9,70	Ø 10,00	30,00	36,00	1,250	-	73,00	.HB
AM.TROCHO.111125.34.12.R0508.03	Ø 11,1125	7/16"	Ø 10,80	Ø 12,00	34,00	38,00	0,508	0,02	84,00	.HB
AM.TROCHO.111125.34.12.R0762.03	Ø 11,1125	7/16"	Ø 10,80	Ø 12,00	34,00	38,00	0,762	0,03	84,00	.HB
AM.TROCHO.111125.34.12.R1016.03	Ø 11,1125	7/16"	Ø 10,80	Ø 12,00	34,00	38,00	1,016	0,04	84,00	.HB
AM.TROCHO.12.36.12.R0500.03	Ø 12,000	-	Ø 11,70	Ø 12,00	36,00	40,00	0,500	-	84,00	.HB
AM.TROCHO.12.36.12.R0750.03	Ø 12,000	-	Ø 11,70	Ø 12,00	36,00	40,00	0,75	-	84,00	.HB
AM.TROCHO.12.36.12.R1000.03	Ø 12,000	-	Ø 11,70	Ø 12,00	36,00	40,00	1,000	-	84,00	.HB
AM.TROCHO.12.36.12.R1250.03	Ø 12,000	-	Ø 11,70	Ø 12,00	36,00	40,00	1,250	-	84,00	.HB
AM.TROCHO.12700.38.14.R0508.03	Ø 12,700	1/2"	Ø 12,40	Ø 14,00	38,00	42,00	0,508	0,02	84,00	.HB
AM.TROCHO.12700.38.14.R0762.03	Ø 12,700	1/2"	Ø 12,40	Ø 14,00	38,00	42,00	0,762	0,03	84,00	.HB
AM.TROCHO.12700.38.14.R1016.03	Ø 12,700	1/2"	Ø 12,40	Ø 14,00	38,00	42,00	1,016	0,04	84,00	.HB
AM.TROCHO.12700.38.14.R1270.03	Ø 12,700	1/2"	Ø 12,40	Ø 14,00	38,00	42,00	1,270	0,05	84,00	.HB
AM.TROCHO.12700.38.14.R1524.03	Ø 12,700	1/2"	Ø 12,40	Ø 14,00	38,00	42,00	1,524	0,06	84,00	.HB
AM.TROCHO.14.43.24.R1000.03	Ø 14,000	-	Ø 13,70	Ø 14,00	43,00	48,00	1,000	-	84,00	.HB
AM.TROCHO.14.43.24.R1250.03	Ø 14,000	-	Ø 13,70	Ø 14,00	43,00	48,00	1,250	-	84,00	.HB
AM.TROCHO.14.43.24.R1500.03	Ø 14,000	-	Ø 13,70	Ø 14,00	43,00	48,00	1,500	-	84,00	.HB
AM.TROCHO.142875.43.16.R0762.03	Ø 14,2875	9/16"	Ø 13,90	Ø 16,00	43,00	48,00	0,762	0,03	83,00	.HB
AM.TROCHO.142875.43.16.R1016.03	Ø 14,2875	9/16"	Ø 13,90	Ø 16,00	43,00	48,00	1,016	0,04	83,00	.HB
AM.TROCHO.142875.43.16.R1270.03	Ø 14,2875	9/16"	Ø 13,90	Ø 16,00	43,00	48,00	1,270	0,05	83,00	.HB
AM.TROCHO.142875.43.16.R1524.03	Ø 14,2875	9/16"	Ø 13,90	Ø 16,00	43,00	48,00	1,524	0,06	83,00	.HB
AM.TROCHO.15875.48.16.R0762.03	Ø 15,875	5/8"	Ø 15,50	Ø 16,00	48,00	52,00	0,762	0,03	83,00	.HB
AM.TROCHO.15875.48.16.R1016.03	Ø 15,875	5/8"	Ø 15,50	Ø 16,00	48,00	52,00	1,016	0,04	83,00	.HB
AM.TROCHO.15875.48.16.R1270.03	Ø 15,875	5/8"	Ø 15,50	Ø 16,00	48,00	52,00	1,270	0,05	83,00	.HB
AM.TROCHO.15875.48.16.R1524.03	Ø 15,875	5/8"	Ø 15,50	Ø 16,00	48,00	52,00	1,524	0,06	83,00	.HB
AM.TROCHO.16.48.16.R1000.03	Ø 16,000	-	Ø 15,70	Ø 16,00	48,00	52,00	1,000	-	83,00	.HB
AM.TROCHO.16.48.16.R1250.03	Ø 16,000	-	Ø 15,70	Ø 16,00	48,00	52,00	1,250	-	83,00	.HB
AM.TROCHO.16.48.16.R1500.03	Ø 16,000	-	Ø 15,70	Ø 16,00	48,00	52,00	1,500	-	83,00	.HB

■ Für einen Fräser mit HB-Schaft ergänzen Sie „HB“ an die Artikelnummer, z. B. AM.TROCHO.04.13.06.R0200.03.HB

Ab Lager lieferbar.

ACTIONMILL[®]
by HB microtec

INOX-Trochoid
ALU-Trochoid
Steel-Trochoid

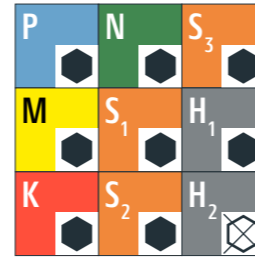

Anwendungsempfehlung Sehr gut geeignet Bedingt geeignet Nicht empfohlen

Werkstoffgruppe	Werkstoffgruppe	Wr.Nr.	DIN	AISI/ASTM/UNS
P	Stähle bis RM < 1200N/mm ²	1.0044	S275JR	AISI 1020
		1.0715	11SMn30	AISI 1215
		1.7131	16MnCr5	AISI 5115
		1.3505	100Cr6	AISI 52100
		1.7225	42CrMo4	AISI 4140
M	Rostfreie Stähle ferritisch, martensitisch, austenitisch	1.4034	X46Cr13	AISI 420C
		1.4542	X5CrNiCuNb 16-4	AISI 630 / ASTM 17-4 PH
		1.4545	X5CrNiCuNb 15-5	ASTM 15-5 PH
		1.4301	X5CrNi 18-10	AISI 304
		1.4435	X2CrNiMo 18-14-3	AISI 316L
K	Gusseisen	0.6020	GG20	ASTM 30
		0.6030	GG30	ASTM 40B
		0.7040	GGG40	ASTM 60-40-18
		0.7060	GGG60	ASTM 80-60-03
N	Nichteisenmetalle	3.2315	AlMgSi1	ASTM 6351
		2.0065	Cu-ETP / CW004A	UNS C11000
		2.0321	CuZn37 CW508L	UNS C27400
		2.0401	CuZn39Pb3 / CW614N	UNS C38500
		2.0966	CuAl10Ni5Fe4	UNS C63000
S (S1, S2, S3)	Hitzebeständige Stähle, Titan, CrCo	2.4617	NiMo28	Hastelloy B-2
		2.4665	NiCr22Fe18Mo	Hastelloy X
		3.7165	TiAl6V4	ASTM B348 / F136
		9.9367	TiAl6Nb7	ASTM F1295
		2.4964	CoCr20W15Ni	Haynes 25
			CrCoMo28	ASTM F1537
H	Stähle gehärtet bis ≥ 55 HRC	1.2510	100MnCrMoW4	AISI O1
		1.2379	X153CrMoV12	AISI D2

ap=L1		ae=0,06xD1		ap=L1		ae=0,06xD1		ap=L1		ae=0,06xD1	
ab Ø 4,0 mm		ab Ø 6,0 mm		ab Ø 8,0 mm		ab Ø 10 mm		ab Ø 12 mm - Ø 16 mm			
vc [m/min]	fz [mm]	vc [m/min]	fz [mm]	vc [m/min]	fz [mm]	vc [m/min]	fz [mm]	vc [m/min]	fz [mm]	vc [m/min]	fz [mm]
100-200	0,02 - 0,035	100-200	0,03 - 0,045	100-200	0,05 - 0,065	100-200	0,06 - 0,075	100-200	0,07 - 0,085		
100-200	0,02 - 0,03	100-200	0,03 - 0,04	100-200	0,05 - 0,055	100-200	0,06 - 0,065	100-200	0,07 - 0,075		
80-110	0,02 - 0,03	80-110	0,035 - 0,045	80-110	0,045 - 0,055	80-110	0,055 - 0,065	80-110	0,065 - 0,075		
70-100	0,015 - 0,025	70-100	0,035 - 0,045	70-100	0,045 - 0,055	70-100	0,055 - 0,065	70-100	0,065 - 0,075		
80-170	0,02 - 0,04	80-170	0,04 - 0,055	80-170	0,05 - 0,065	80-170	0,06 - 0,065	80-170	0,065 - 0,085		
80-160	0,02 - 0,04	80-160	0,035 - 0,06	80-160	0,055 - 0,06	80-160	0,055 - 0,06	80-160	0,065 - 0,075		
100-200	0,02 - 0,045	100-200	0,035 - 0,06	100-200	0,055 - 0,06	100-200	0,055 - 0,06	100-200	0,065 - 0,08		
80-120	0,02 - 0,045	80-120	0,035 - 0,06	80-120	0,055 - 0,06	80-120	0,055 - 0,06	80-120	0,065 - 0,085		
50 - 80	0,02 - 0,03	50 - 80	0,03 - 0,04	50 - 80	0,03 - 0,05	50 - 80	0,04 - 0,06	50 - 80	0,05 - 0,07		
40-70	0,02 - 0,03	40-70	0,03 - 0,04	40-70	0,03 - 0,05	40-70	0,04 - 0,06	40-70	0,05 - 0,07		
25-40	0,02 - 0,03	25-60	0,03 - 0,04	25-60	0,03 - 0,05	25-60	0,04 - 0,06	25-70	0,05 - 0,07		
keine Angaben eingetragen											
keine Angaben eingetragen											

ACTIONMILL[®]

by HB microtec *Trochoid*



HBMicrotec[®]
ACTIONTOOLS & ENGINEERING

HB microtec GmbH & Co. KG

Bischof-Sproll-Straße 6

78532 Tuttlingen

Germany

Tel. +49 7461 1657280

Fax +49 7461 1657281

E-Mail kontakt@hb-microtec.de

Web www.HB-microtec.de

