

Back-Chamfer

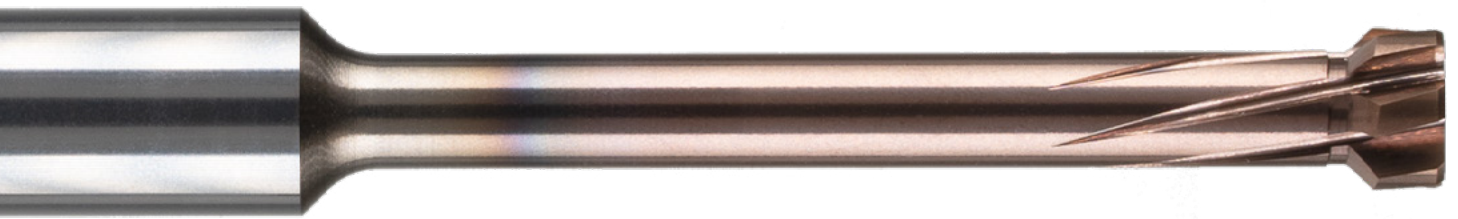

TARGETMILL[®]
by HB microtec *Back-Chamfer*

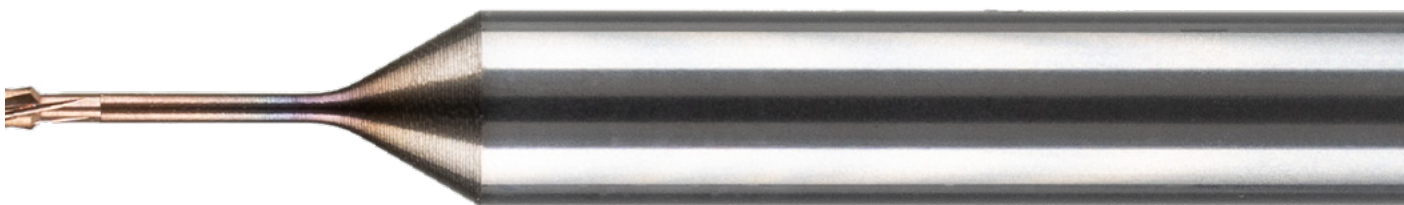

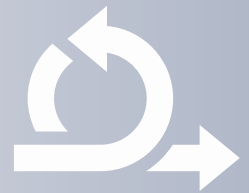
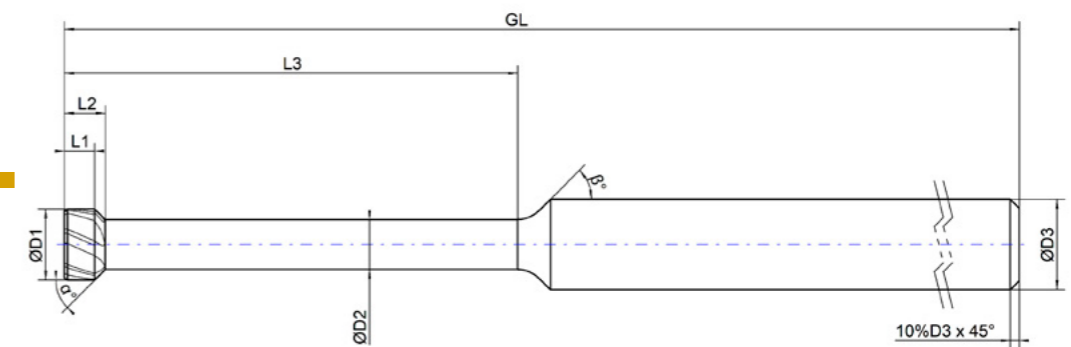
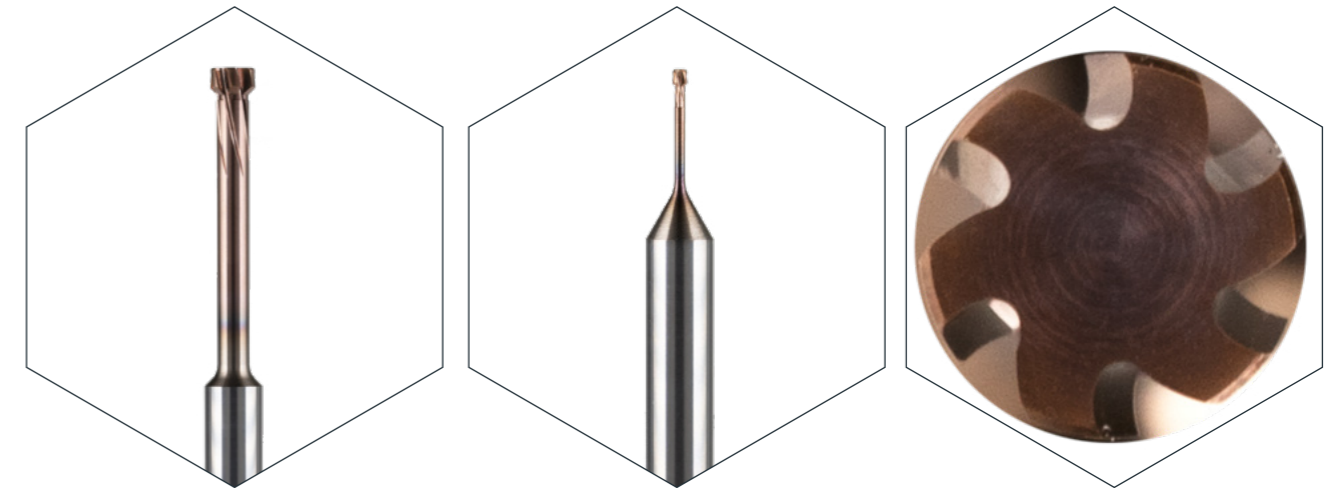
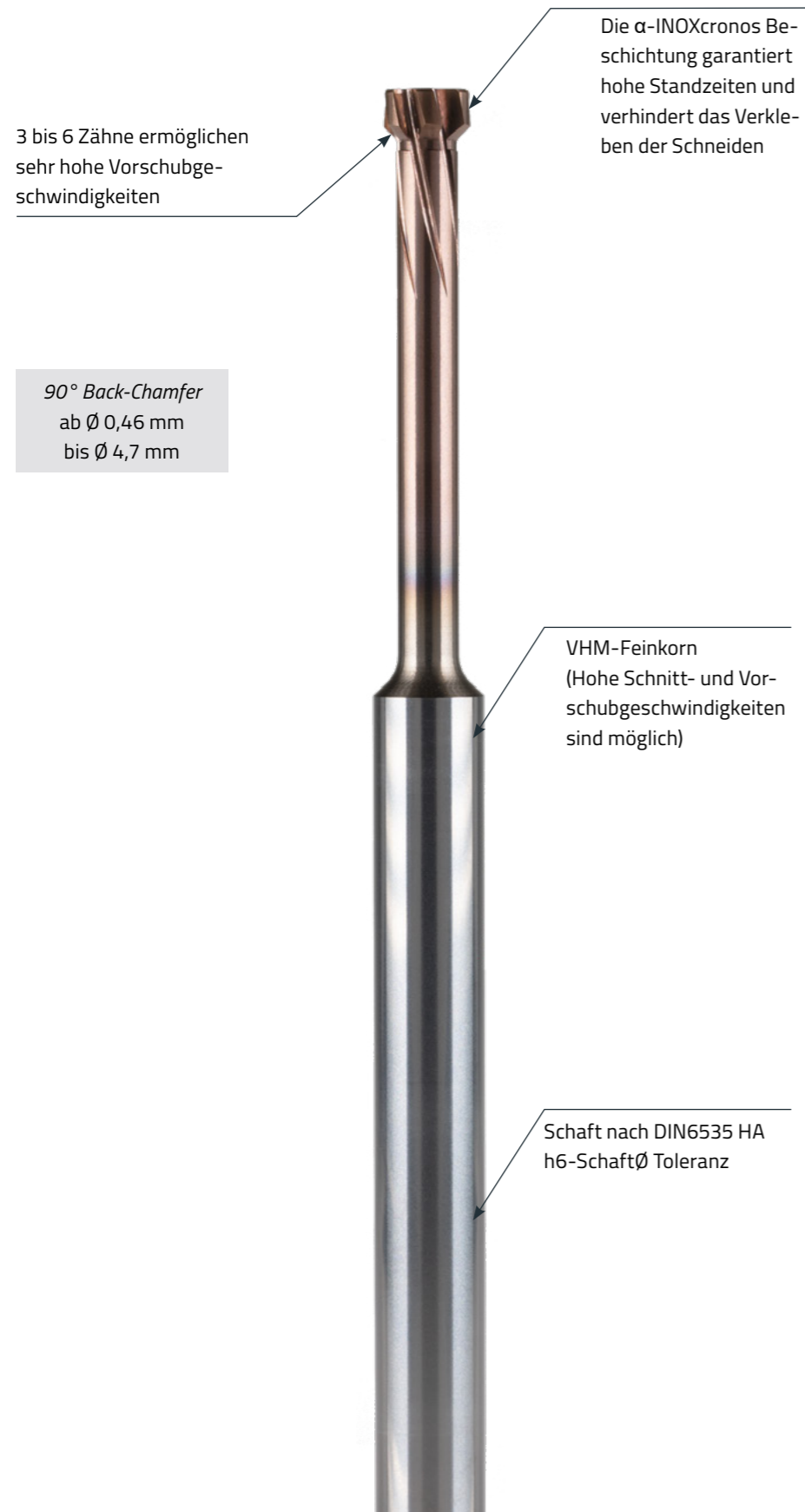

Anfrage

Bestellung Bestellnummer: _____ Sonstiges: _____

Abmessungen: D ₁ : _____ GL: _____ α : _____ D ₂ : _____ L ₁ : _____ β : _____ D ₃ : _____ L ₂ : _____ Z: _____ L ₃ : _____	Beschichtung: Beschichtet*: _____ Unbeschichtet	Mit Kühlkanälen? Ja Nein	
		Schneidrichtung: Links Rechts	
		Menge: _____	
Zu zerspanender Werkstoff: _____		Schaftform: _____	
Datum, Unterschrift & Firmenstempel: _____		Kontaktperson: _____	

* Ohne weitere Angaben wird die am besten passende Beschichtung verwendet.

Back-Chamfer

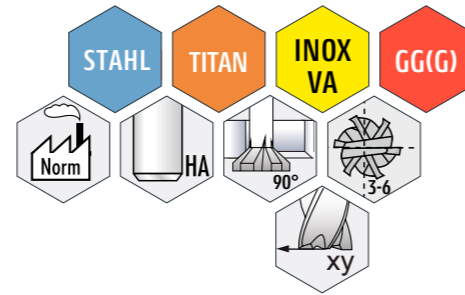

TARGETMILL
TM.BC.046.048
Back-Chamfer
L1: 0,48 mm
D1: Ø0,46 mm

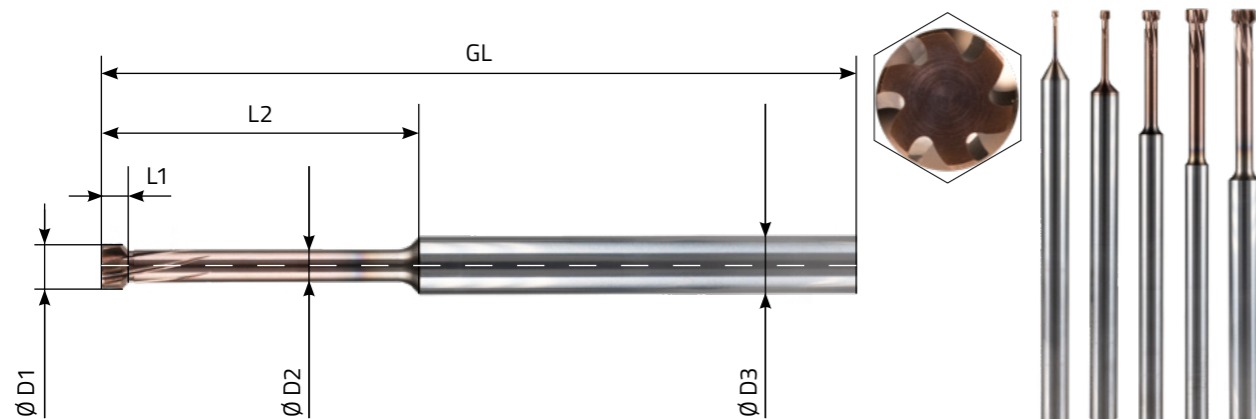

5x PLUS für den TARGETMILL:

- „Micro“-Entgrater ab Ø 0,46 mm bis Ø 4,7 mm
- Rückwärtsentgrater für Bohrungen ab Ø 0,5 mm
- Es entstehen keine Sekundärgräte
- Universell einsetzbar in den unterschiedlichsten Materialien
- 3 bis 6 Zähne sorgen für hervorragende Oberflächenqualitäten

Artikelnummer	Beschichtung	Zähne	D1 (mm)	D2 (mm)	D3 h6 (mm)	L1 (mm)	L2 (mm)	GL (mm)
TM.BC.046.048	α-INOX	3	Ø 0,46	Ø 0,30	Ø 3,00	0,48	3,00	50,00
TM.BC.090.100	α-INOX	4	Ø 0,90	Ø 0,60	Ø 4,00	1,00	6,00	60,00
TM.BC.140.133	α-INOX	4	Ø 1,40	Ø 0,95	Ø 4,00	1,33	9,00	60,00
TM.BC.290.190	α-INOX	5	Ø 2,90	Ø 2,10	Ø 4,00	1,90	18,00	70,00
TM.BC.370.250	α-INOX	5	Ø 3,70	Ø 2,70	Ø 4,00	2,50	24,00	70,00
TM.BC.470.270	α-INOX	6	Ø 4,70	Ø 3,30	Ø 6,00	2,70	30,00	80,00

Ab Lager lieferbar.

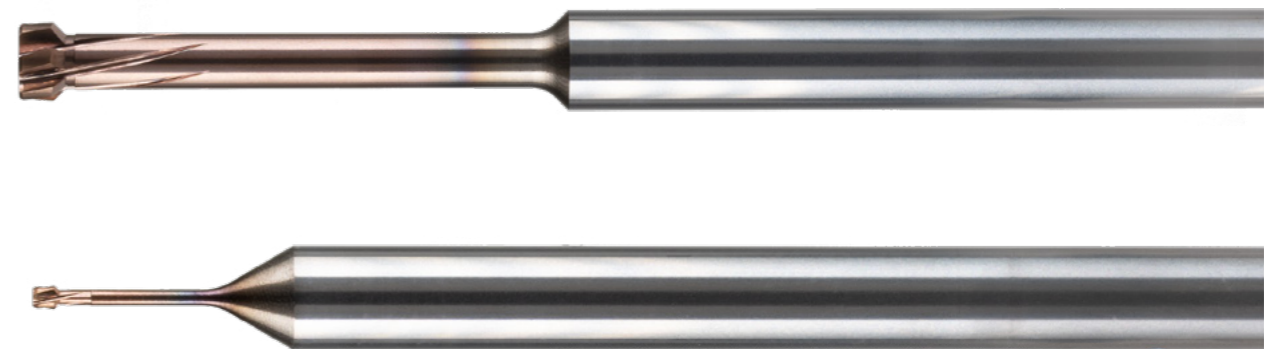

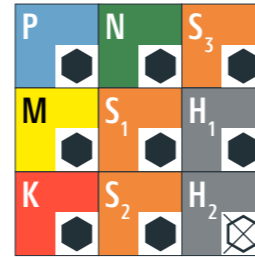

Anwendungsempfehlung Sehr gut geeignet Bedingt geeignet Nicht empfohlen

Werkstoffgruppe	Werkstoffgruppe	Wr.Nr.	DIN	AISI/ASTM/UNS
P	Stähle bis RM < 1200N/mm ²	1.0044	S275JR	AISI 1020
		1.0715	11Mn30	AISI 1215
		1.7131	16MnCr5	AISI 5115
		1.3505	100Cr6	AISI 52100
		1.7225	42CrMo4	AISI 4140
M	Rostfreie Stähle ferritisch, martensitisch, austenitisch	1.4034	X46Cr13	AISI 420C
		1.4542	X5CrNiCuNb 16-4	AISI 630 / ASTM 17-4 PH
		1.4545	X5CrNiCuNb 15-5	ASTM 15-5 PH
		1.4301	X5CrNi 18-10	AISI 304
		1.4435	X2CrNiMo 18-14-3	AISI 316L
K	Gusseisen	0.6020	GG20	ASTM 30
		0.6030	GG30	ASTM 40B
		0.7040	GGG40	ASTM 60-40-18
		0.7060	GGG60	ASTM 80-60-03
N	Nichteisenmetalle	3.2315	AlMgSi1	ASTM 6351
		2.0065	Cu-ETP / CW004A	UNS C11000
		2.0321	CuZn37 CW508L	UNS C27400
		2.0401	CuZn39Pb3 / CW614N	UNS C38500
		2.0966	CuAl10Ni5Fe4	UNS C63000
S (S1, S2, S3)	Hitzebeständige Stähle, Titan, CrCo	2.4617	NiMo28	Hastelloy B-2
		2.4665	NiCr22Fe18Mo	Hastelloy X
		3.7165	TiAl6V4	ASTM B348 / F136
		9.9367	TiAl6Nb7	ASTM F1295
		2.4964	CoCr20W15Ni	Haynes 25
H	Stähle gehärtet bis ≥ 55 HRC	1.2510	100MnCrMoW4	AISI O1
		1.2379	X153CrMoV12	AISI D2

Ø 0,46 - Ø 1,4 mm		Ø 2,9 - Ø 3,7 mm		Ø 4,7 mm	
vc [m/min]	fz [mm]	vc [m/min]	fz [mm]	vc [m/min]	fz [mm]
100-140	0,02 - 0,035	100-140	0,02 - 0,045	100-140	0,025 - 0,065
100-140	0,02 - 0,03	100-140	0,02 - 0,04	100-140	0,025 - 0,055
80-110	0,01 - 0,03	80-110	0,015 - 0,045	80-110	0,025 - 0,055
70-100	0,01 - 0,025	70-100	0,015 - 0,045	70-100	0,025 - 0,055
80-140	0,01 - 0,04	80-140	0,02 - 0,055	80-140	0,03 - 0,065
80-160	0,02 - 0,04	80-160	0,035 - 0,06	80-160	0,025 - 0,06
80-140	0,02 - 0,045	80-140	0,035 - 0,06	80-140	0,025 - 0,06
80-120	0,02 - 0,045	80-120	0,035 - 0,06	80-120	0,025 - 0,06
50 - 80	0,008 - 0,015	50 - 80	0,015 - 0,04	50 - 80	0,02 - 0,05
50-80	0,008 - 0,015	50-80	0,015 - 0,04	50-80	0,02 - 0,05
50-80	0,008 - 0,015	50-80	0,015 - 0,04	50-80	0,02 - 0,05
keine Angaben eingetragen					
keine Angaben eingetragen					

TARGETMILL[®]

by HB microtec

Back-Chamfer



HB^Microtec[®]
ACTIONTOOLS & ENGINEERING

HB microtec GmbH & Co. KG

Katharinenstraße 2

78532 Tuttlingen

Germany

Tel. +49 7461 1657280

Fax +49 7461 1657281

E-Mail kontakt@hb-microtec.de

Web www.HB-microtec.de

