

INOX-Front-Chamfer

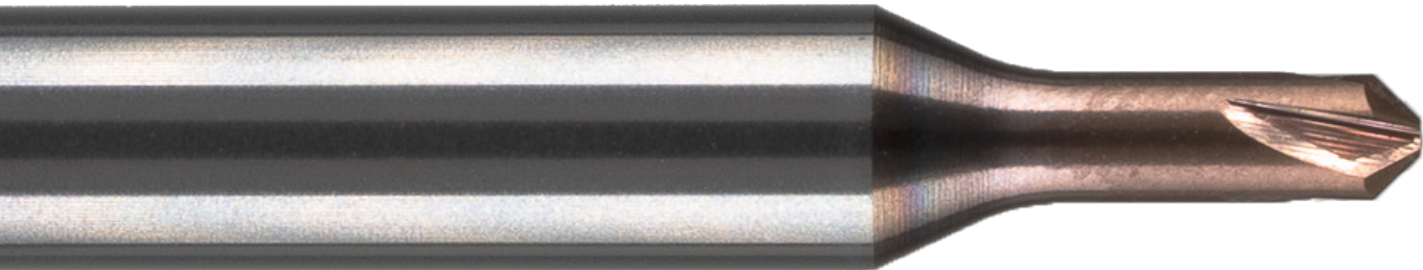

ACTIONMILL[®]
by HB microtec *INOX-Front-Chamfer*

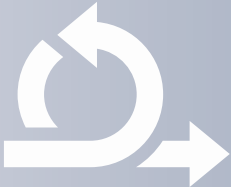

4 bis 6 Zähne ermöglichen
sehr hohe Vorschubge-
schwindigkeiten

Die α -INOXcronos Be-
schichtung garantiert
hohe Standzeiten und
verhindert das Verkle-
ben der Schneiden

90° Front-Chamfer
ab \varnothing 0,5 mm
bis \varnothing 8,0 mm

VHM-Feinkorn
(Hohe Schnitt- und Vor-
schubgeschwindigkeiten
sind möglich)

Schaft nach DIN6535 HA
h6-Schaft \varnothing Toleranz

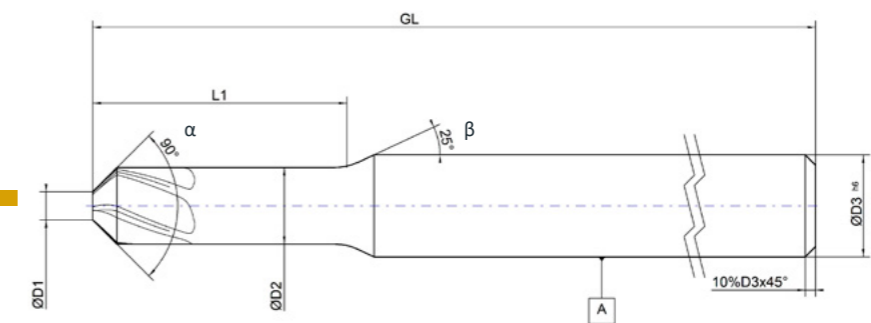
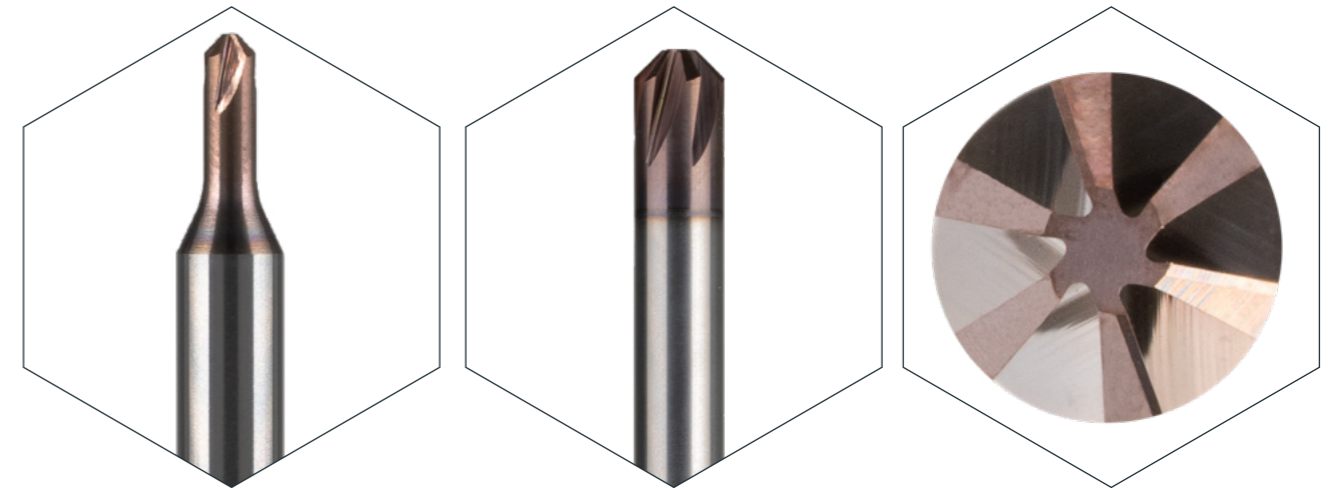

Anfrage

Bestellung Bestellnummer: _____ Sonstiges: _____

Abmessungen: D ₁ : _____ GL: _____ α : _____ D ₂ : _____ L ₁ : _____ β : _____ D ₃ : _____ Z: _____		Beschichtung: Beschichtet*: _____ Unbeschichtet		Mit Kühlkanälen? Ja Nein	
Zu zerspanender Werkstoff: _____		Schaftform: _____		Schneidrichtung: Links Rechts	
Menge: _____		Datum, Unterschrift & Firmenstempel: _____			
Kontaktperson: _____				_____	

* Ohne weitere Angaben wird die am besten passende Beschichtung verwendet.

INOX-Front-Chamfer

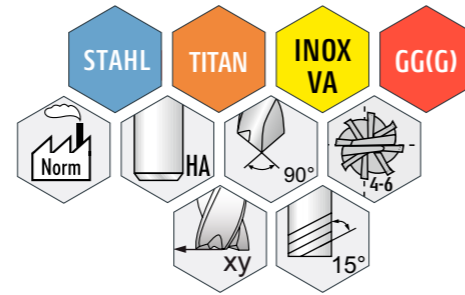

ACTIONMILL
AM.FC.050.90
Front-Chamfer
D2: Ø0,50 mm
90° Spitzenwinkel

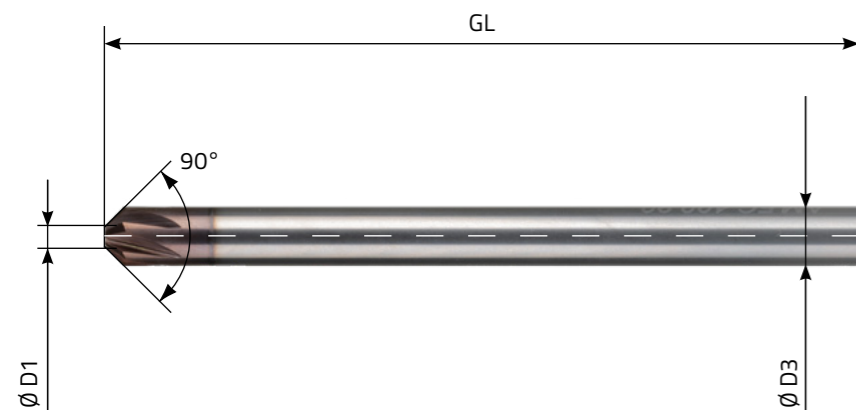
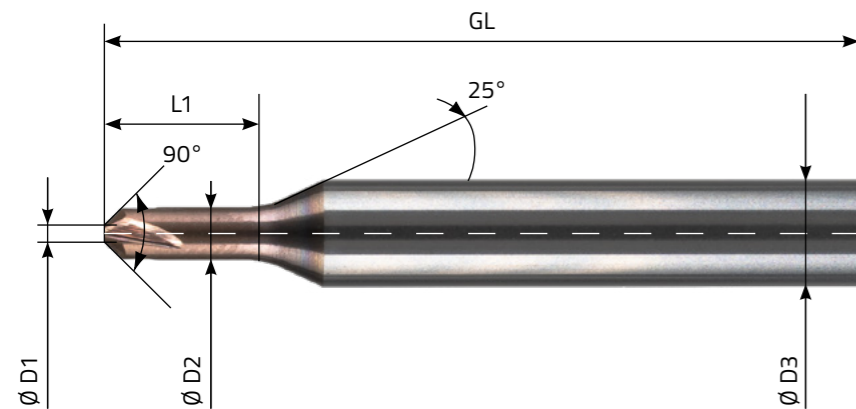

Artikelnummer	Beschichtung	Zähne	D1 (mm)	D2 (mm)	D3 (mm)	L1 (mm)	GL (mm)
AM.FC.050.90	α-INOX	4	Ø 0,20	Ø 0,50	Ø 4,00	3,00	55,00
AM.FC.100.90	α-INOX	4	Ø 0,30	Ø 1,00	Ø 4,00	3,00	55,00
AM.FC.200.90	α-INOX	4	Ø 0,60	Ø 2,00	Ø 4,00	6,00	55,00
AM.FC.300.90	α-INOX	5	Ø 1,00	Ø 3,00	Ø 4,00	9,00	55,00
AM.FC.400.90	α-INOX	6	Ø 1,50	-	Ø 4,00	-	55,00
AM.FC.600.90	α-INOX	6	Ø 2,00	-	Ø 6,00	-	57,00
AM.FC.800.90	α-INOX	6	Ø 2,50	-	Ø 8,00	-	58,00

Ab Lager lieferbar.

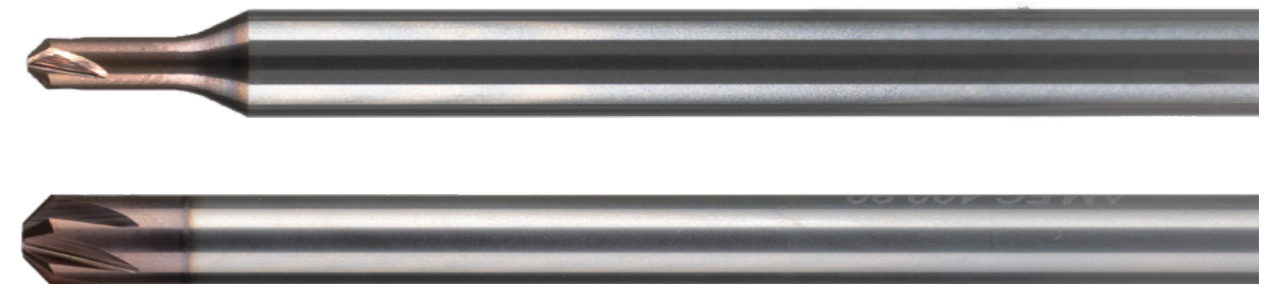

5x PLUS für den ACTIONMILL:

- „Micro“-Frontentgrater ab Ø 0,5 mm bis Ø 8,0 mm
- Entgraten, Fasen von Kanten, Nuten, Bohrungen und Gewinden
- Verstärkte Ausführung für lange Standzeiten
- Universell einsetzbar in den unterschiedlichsten Materialien
- 4 bis 6 Zähne sorgen für hervorragende Oberflächenqualitäten

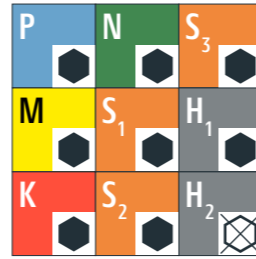

Anwendungsempfehlung Sehr gut geeignet Bedingt geeignet Nicht empfohlen

Werkstoffgruppe	Werkstoffgruppe	Wr.Nr.	DIN	AISI/ASTM/UNS
P	Stähle bis RM < 1200N/mm ²	1.0044	S275JR	AISI 1020
		1.0715	11Mn30	AISI 1215
		1.7131	16MnCr5	AISI 5115
		1.3505	100Cr6	AISI 52100
		1.7225	42CrMo4	AISI 4140
M	Rostfreie Stähle ferritisch, martensitisch, austenitisch	1.4034	X46Cr13	AISI 420C
		1.4542	X5CrNiCuNb 16-4	AISI 630 / ASTM 17-4 PH
		1.4545	X5CrNiCuNb 15-5	ASTM 15-5 PH
		1.4301	X5CrNi 18-10	AISI 304
		1.4435	X2CrNiMo 18-14-3	AISI 316L
K	Gusseisen	0.6020	GG20	ASTM 30
		0.6030	GG30	ASTM 40B
		0.7040	GGG40	ASTM 60-40-18
		0.7060	GGG60	ASTM 80-60-03
N	Nichteisenmetalle	3.2315	AlMgSi1	ASTM 6351
		2.0065	Cu-ETP / CW004A	UNS C11000
		2.0321	CuZn37 CW508L	UNS C27400
		2.0401	CuZn39Pb3 / CW614N	UNS C38500
		2.0966	CuAl10Ni5Fe4	UNS C63000
S (S1, S2, S3)	Hitzebeständige Stähle, Titan, CrCo	2.4617	NiMo28	Hastelloy B-2
		2.4665	NiCr22Fe18Mo	Hastelloy X
		3.7165	TiAl6V4	ASTM B348 / F136
		9.9367	TiAl6Nb7	ASTM F1295
		2.4964	CoCr20W15Ni	Haynes 25
			CrCoMo28	ASTM F1537
H	Stähle gehärtet bis ≥ 55 HRC	1.2510	100MnCrMoW4	AISI O1
		1.2379	X153CrMoV12	AISI D2

Ø 0,5 - Ø 2 mm		Ø 3 - Ø 4 mm		Ø 6 - Ø 8 mm	
vc [m/min]	fz [mm]	vc [m/min]	fz [mm]	vc [m/min]	fz [mm]
100-140	0,02 - 0,035	100-140	0,02 - 0,045	100-140	0,05 - 0,065
100-140	0,02 - 0,03	100-140	0,02 - 0,04	100-140	0,05 - 0,055
80-110	0,01 - 0,03	80-110	0,015 - 0,045	80-110	0,045 - 0,055
70-100	0,01 - 0,025	70-100	0,015 - 0,045	70-100	0,045 - 0,055
80-140	0,01 - 0,04	80-140	0,02 - 0,055	80-140	0,05 - 0,065
80-160	0,02 - 0,04	80-160	0,035 - 0,06	80-160	0,055 - 0,06
80-140	0,02 - 0,045	80-140	0,035 - 0,06	80-140	0,055 - 0,06
80-120	0,02 - 0,045	80-120	0,035 - 0,06	80-120	0,055 - 0,06
50 - 80	0,008 - 0,015	50 - 80	0,015 - 0,04	50 - 80	0,03 - 0,05
50-80	0,008 - 0,015	50-80	0,015 - 0,04	50-80	0,03 - 0,05
50-80	0,008 - 0,015	50-80	0,015 - 0,04	50-80	0,03 - 0,05
keine Angaben eingetragen					
keine Angaben eingetragen					

ACTIONMILL®

by HB microtec *INOX-Front-Chamfer*



HBMicrotec®
ACTIONTOOLS & ENGINEERING

HB microtec GmbH & Co. KG

Katharinenstraße 2

78532 Tuttlingen

Germany

Tel. +49 7461 1657280

Fax +49 7461 1657281

E-Mail kontakt@hb-microtec.de

Web www.HB-microtec.de

